

## FITTING INSTRUCTION

Clamp mark in acc. with		Cables joining
ISO	PN	
1	L	Left directional lights
2	+	Rear fog lights
3	31	Ground
4	R	Right directional lights
5	58R	Right side parking lights
6	54	Stoplights
7	58L	Left side parking lights

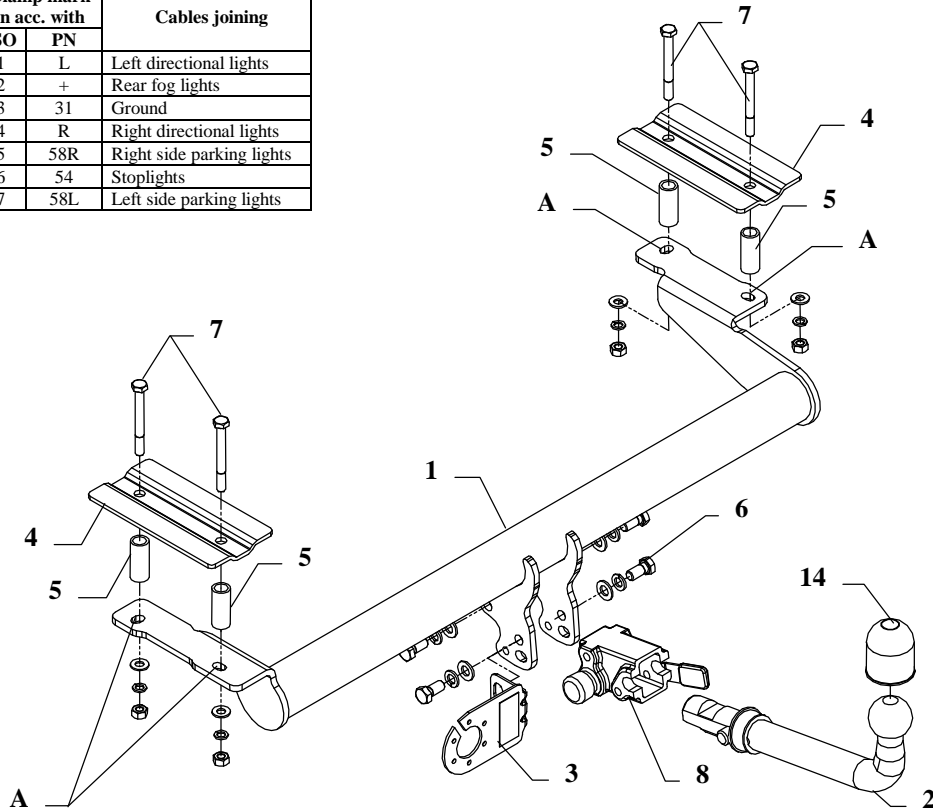

This towbar is designed to assembly in following cars:  
**FORD ESCORT III 3/5 doors**, produced since 10.1992 till 12.1995, catalogue no. **C09A** and is prepared to tow trailers max total weight **1200 kg** and max vertical load **50kg**.

### *From manufacturer*

Thank you for buying our product. Their reliability has been confirmed in many tests. Reliability of towbar depends also on correct assembly and right operation. For this reasons we kindly ask to read carefully this instruction and apply to hints.

*The towbar should be install in points described by a car producer.*

## The instruction of the assembly

1. To install our towbar it is not necessary to disassemble a rear bumper.
2. In factory marked points (inside trunk, left and right side) knock out per two plugs  $\varnothing 24\text{mm}$  (use circular rod or something similar). In maked holes slipdistance sleeves L=50mm (pos. 5) and next put elments (pos. 4) from towbar accessories.
3. Put main bar of towbar (pos. 1) from below the car and through holes (pos. A), distance sleeves and fish-plates (pos. 4) screw using bolts M10x90mm (pos. 7).
4. Tighten all bolts according to the torque shown in the table.
5. Fix body of the automat (pos. 8) and the socket plate (pos. 3) using bolts M12x25mm (pos. 6) from accessories. Place towball (pos. 2) according to supplied instruction.
6. Connect electric wires of 7-poles socket according to the instruction of the car. (Recommend to make at authorized service station).
7. Complete the paint coating damaged during installation.

Torque settings for nuts and bolts (8,8):

<b>M8</b>	25 Nm	<b>M10</b>	55 Nm
<b>M12</b>	85 Nm	<b>M14</b>	135 Nm









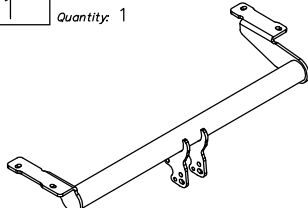

## NOTE

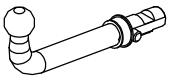
After install the towbar you should get adequate note in registration book (at authorised service station).The car should be equipped with:

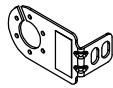
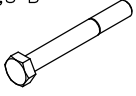
- Indicators
- Tow mirrors

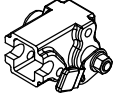
After 1000km check all bolts and nuts. The ball of towbar must be always kept clear and conserve with a grease.

## Towbar accessories:

Pos. 1	Name: Main bar Quantity: 1	Pos. 5	Name: Distance sleeve Quantity: 4 Dim.: Ø21,3x2,65; L=50mm	Pos. 10	Name: Plain washer Quantity: 4 Dim.: Ø 13 mm
					
Pos. 2	Name: Tow ball Quantity: 1	Pos. 6	Name: Bolt 8,8 B Quantity: 4 Dim.: M12x25mm	Pos. 11	Name: Plain washer Quantity: 4 Dim.: Ø 10,5 mm
					
Pos. 3	Name: Socket plate Quantity: 1	Pos. 7	Name: Bolt 8,8 B Quantity: 4 Dim.: M10x90mm	Pos. 12	Name: Spring washer Quantity: 4 Dim.: Ø 12,2 mm
					
Pos. 4	Name: Fish-plate of bracket Quantity: 2 Dim.: 100x200x10mm	Pos. 8	Name: Body of the automat Quantity: 1	Pos. 13	Name: Spring washer Quantity: 4 Dim.: Ø 10,2 mm
					
Pos. 9	Name: Nut 8 B Quantity: 4 Dim.: M10	Pos. 14	Name: Ball cover Quantity: 1	Pos. 15	Name: Body plug Quantity: 1
					



## PPUH AUTO-HAK S.J.

Produkcja Haków Holowniczych  
Henryk & Zbigniew Nejman  
76-200 SŁUPSK ul. Słoneczna 16K  
tel/fax (059) 8-414-414; 8-414-413  
e-mail: [office@autohak.com.pl](mailto:office@autohak.com.pl)  
[www.autohak.com.pl](http://www.autohak.com.pl)

## Towing hitch (without electrical set)

Class: **A50-X** Cat. no. **C09A**

Designed for:

Manufacturer: **FORD**

Model: **ESCORT III**

Type: **3/5doors**

produced since 10.1992 till 12.1995

Technical data:

**D-value: 6,73 kN**

maximum trailer weight: **1200 kg**

maximum vertical cup load: **50 kg**

Approval number acc. to regulations EKG/ONZ 55.01: **E20-55R-01 1168**

## Foreword

This towbar is designed according to rules of safety traffic regulations. The towing hitch is a safety component and can be install only by qualified personnel. Any alteration or conversion of the towing hitch is prohibited and would lead to cancellation of design certification. Remove insulating compound and underseal from vehicle (if present) in the area of the matting surfaces of the towing hitch.

The vehicle manufacturer's specifications regarding trailer load and max. vertical cup load are decisive for driving, and values for the towing hitch cannot be exceeded.

*D-value formula:*

$$\frac{\text{Max trailer weight [kg]} \times \text{Max vehicle weight [kg]}}{\text{Max trailer weight [kg]} + \text{Max vehicle weight [kg]}} \times \frac{9,81}{1000} = D \text{ [kN]}$$