

FITTING INSTRUCTION

Clamp mark in acc. with		Cables joining
ISO	PN	
1	L	Left directional lights
2	+	Rear fog lights
3	31	Ground
4	R	Right directional lights
5	58R	Right side parking lights
6	54	Stoplights
7	58L	Left side parking lights

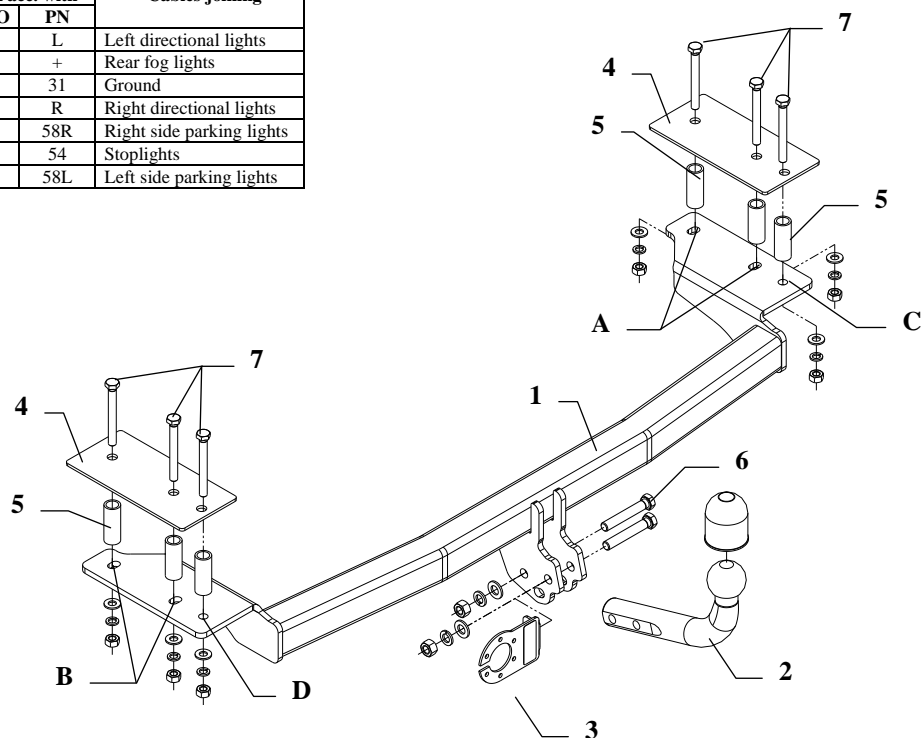

This towbar is designed to assembly in following cars:
FORD ESCORT I, 3/5 doors, produced since 01.1986 till 09.1990, catalogue no. **C007** and is prepared to tow trailers max total weight **1200 kg** and max vertical mass **50 kg**.

From manufacturer

Thank you for buying our product. Their reliability has been confirmed in many tests. Reliability of towbar depends also on correct assembly and right operation. For this reasons we kindly ask to read carefully this instruction and apply to hints.

The towbar should be install in points described by a car producer.

The instruction of the assembly

1. Put the main bar of the towbar (pos. 1) to chassis members in this way, so original holes in chassis members agree to holes in bar of the towbar (pos. A and B), next through holes (pos. C and D) drill holes inside trunk, use drill $\varnothing 10,5\text{mm}$.
2. From inside, above holes (pos. A and B) are original plugged holes. Make them open using some kind of rod. Holes (pos. C and D) drill again using drill $\varnothing 22\text{mm}$ (**only in upper wall!**).
3. In prepared holes (pos. A, B, C, D) slip distance sleeves (pos. 5) from accessories (see drawing), next put over fish-plates (pos. 4), put bolts M10x90mm (pos. 7), next put the main bar of the towbar (pos. 1) and fix all together.
4. Fix tow-ball (pos. 2) with socket plate (pos. 3) using bolts M12x75mm (pos. 6) from accessories.
5. Tighten all bolts according to the torque shown in the table.
6. Connect electric wires of 7-poles socket according to the instruction of the car. (Recommend to make at authorized service station).
7. Complete paint layer damaged during installation.

Torque settings for nuts and bolts (8,8):	
M 8 - 25 Nm	M 10 - 55 Nm
M 12 - 85 Nm	M 14 - 135 Nm

NOTE

After install the towbar you should get adequate note in registration book (at authorised service station).The car should be equipped with:

- Indicators
- Tow mirrors

After 1000km of exploitation check all bolts and nuts. The ball of towbar must be always kept clear and conserve with a grease.

Towbar accessories:

Pos. 1	Name: Main bar Quantity: 1	Pos. 5	Name: Distance sleeve Quantity: 6 Dim.: $\varnothing 21.3 \times 2.35 \text{ mm}$ L=55mm	Pos. 10	Name: Plain washer Quantity: 2 Dim.: $\varnothing 13 \text{ mm}$
Pos. 2	Name: Tow ball Quantity: 1	Pos. 6	Name: Bolt 8,8 B Quantity: 2 Dim.: M12x75mm	Pos. 11	Name: Plain washer Quantity: 6 Dim.: $\varnothing 10,5 \text{ mm}$
		Pos. 7	Name: Bolt 8,8 B Quantity: 6 Dim.: M10x90mm	Pos. 12	Name: Spring washer Quantity: 2 Dim.: $\varnothing 12,2 \text{ mm}$
Pos. 3	Name: Socket plate Quantity: 1	Pos. 8	Name: Nut 8 B Quantity: 2 Dim.: M12	Pos. 13	Name: Spring washer Quantity: 6 Dim.: $\varnothing 10,2 \text{ mm}$
Pos. 4	Name: Fish-plate Quantity: 2	Pos. 9	Name: Nut 8 B Quantity: 6 Dim.: M10	Pos. 14	Name: Ball cover Quantity: 1



PPUH AUTO-HAK S.J.

Produkcja Zaczepów Kulowych
Henryk & Zbigniew Nejman
76-200 SŁUPSK ul. Słoneczna 16K
tel/fax (059) 8-414-414; 8-414-413
E-mail: office@autohak.com.pl
www.autohak.com.pl

Towing hitch (without electrical set)

Class: **A50-X** Cat. no. **C007**

Designed for:

Manufacturer: **FORD**

Model: **ESCORT I**

Type: **3/5 doors**

produced since 01.1986 till 09.1990

Technical data:

D-value: 6,50 kN

maximum trailer weight: **1200 kg**

maximum vertical cup mass: **50 kg**

Approval number acc. to regulations EKG/ONZ 55.01: E20-55R-01 1461

Foreword

This towbar is designed according to rules of safety traffic regulations. The towing hitch is a safety component and can be install only by qualified personnel. Any alteration or conversion of the towing hitch is prohibited and would lead to cancellation of design certification. Remove insulating compound and underseal from vehicle (if present) in the area of the matting surfaces of the towing hitch. The vehicle manufacturer's specifications regarding trailer load and max. vertical cup load are decisive for driving whereat values for the towing hitch cannot be exceeded.

D-value formula:

$$\frac{\text{Max trailer weight [kg]} \times \text{Max vehicle weight [kg]}}{\text{Max trailer weight [kg]} + \text{Max vehicle weight [kg]}} \times \frac{9,81}{1000} = D \text{ [kN]}$$