

FITTING INSTRUCTION

Clamp mark in acc. with		Cables joining
ISO	PN	
1	L	Left directional lights
2	+	Rear fog lights
3	31	Ground
4	R	Right directional lights
5	58R	Right side parking lights
6	54	Stoplights
7	58L	Left side parking lights

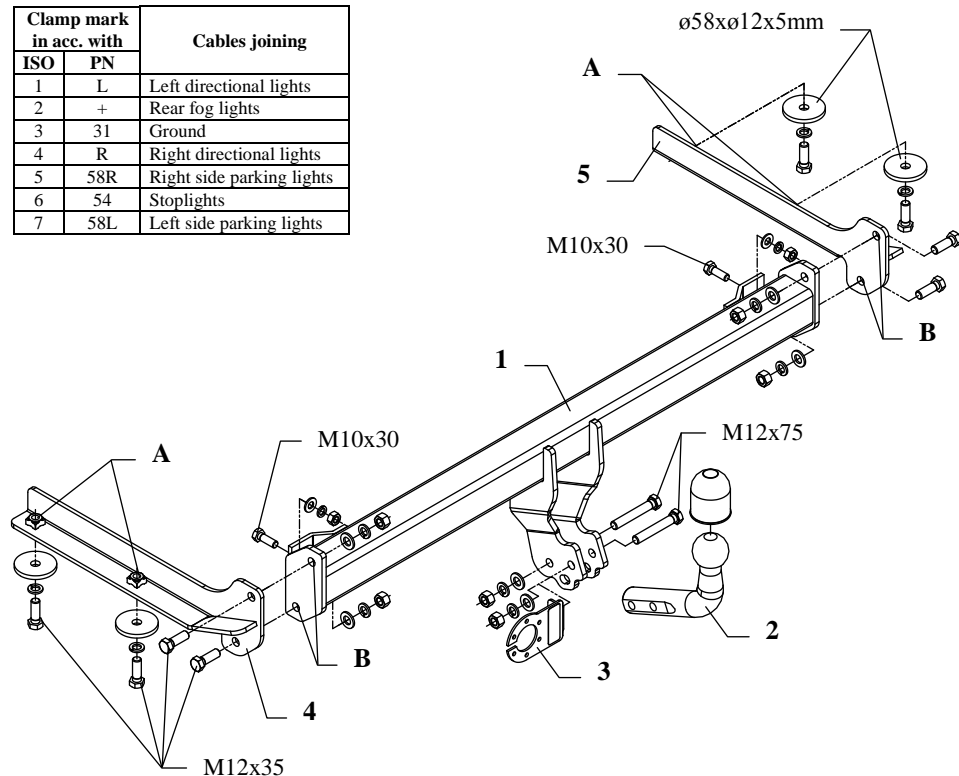

This towbar is designed to assembly in following cars:
HONDA CIVIC, 5 doors, British version, produced since 04.1997 till 02.2001, catalogue no. **Y15** and is prepared to tow trailers max total weight **1200 kg** and max vertical load **50 kg**.

From manufacturer

Thank you for buying our product. Their reliability has been confirmed in many tests. Reliability of towbar depends also on correct assembly and right operation. For this reasons we kindly ask to read carefully this instruction and apply to hints.

The towbar should be install in points described by a car producer.

The instruction of the assembly

1. To mount the towbar, first unscrew the bumper, an then unscrew two dummies in the chassis of the car, situated in the rear piece.
2. Put brackets (pos. 4 and 5) inside the chassis and next, twist from the down side with M12x35mm (pos. 8) bolts, and the washers (pos. 6). Coincide and twist loosely through holes in chassis members and holes (pos. A) in brackets.
3. Twist the main bar of the towbar (pos. 1) with mounted brackets (pos. 4 and 5) through holes (pos. B) using bolts M12x35mm (pos. 8).
4. Mount the bumper after cut out of its fragment 85x75mm, as shown on the drawing. This is marked by the manufacturer of the car.

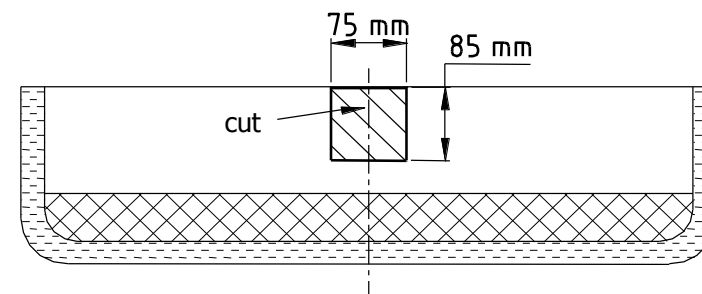

5. To the installed bar, mount the tow-ball (pos. 2) with socket plate (pos. 3) using bolts M12x75mm (pos. 7).
6. Tighten all bolts according to the torque shown in the table.
7. Connect electric wires of 7-poles socket according to the instruction of the car. (Recommend to make at authorized service station).
8. Complete paint layer damaged during installation.

Torque settings for nuts and bolts (8,8):

M 8 - 25 Nm	M 10 - 55 Nm
M 12 - 85 Nm	M 14 - 135 Nm











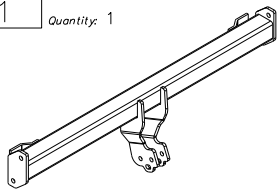
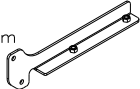

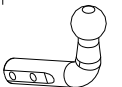
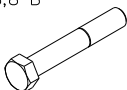

NOTE

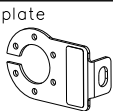
After install the towbar you should get adequate note in registration book (at authorised service station).The car should be equipped with:

- Indicators
- Tow mirrors

After 1000km check all bolts and nuts. The ball of towbar must be always kept clear and conserve with a grease.

Towbar accessories:

Pos. 1 Name: Main bar Quantity: 1 	Pos. 5 Name: Right bracket Quantity: 1 Dim.: 448x128x6mm 	Pos. 11 Name: Nut 8 B Quantity: 2 Dim.: M10 
	Pos. 6 Name: Washer Quantity: 4 Dim.: Ø58xØ12x5mm 	Pos. 12 Name: Plain washer Quantity: 6 Dim.: Ø 13 mm 
Pos. 2 Name: Tow ball Quantity: 1 	Pos. 7 Name: Bolt 8,8 B Quantity: 2 Dim.: M12x75mm 	Pos. 13 Name: Plain washer Quantity: 2 Dim.: Ø 10,5 mm 
Pos. 3 Name: Socket plate Quantity: 1 	Pos. 8 Name: Bolt 8,8 B Quantity: 8 Dim.: M12x35mm 	Pos. 14 Name: Spring washer Quantity: 10 Dim.: Ø 12,2 mm 
Pos. 4 Name: Left bracket Quantity: 1 Dim.: 448x128x6mm 	Pos. 9 Name: Bolt 8,8 B Quantity: 2 Dim.: M10x30mm 	Pos. 15 Name: Spring washer Quantity: 2 Dim.: Ø 10,2 mm 
	Pos. 10 Name: Nut 8 B Quantity: 6 Dim.: M12 	Pos. 16 Name: Ball cover Quantity: 1 



PPUH AUTO-HAK S. J.

Produkcja Haków Holowniczych
Henryk i Zbigniew Nejman
76-200 SŁUPSK ul. Słoneczna 16K
tel/fax (059) 8-414-414; 8-414-413
E-mail: office@autohak.com.pl
www.autohak.com.pl

Towing hitch (without electrical set)

Class: **A50-X** Cat. no. **Y15**

Designed for:

Manufacturer: **HONDA**

Model: **CIVIC**

Type: **5 doors, British version**

produced since 04.1997 till 02.2001

Technical data:

D-value: 6,9 kN

maximum trailer weight: **1200 kg**

maximum vertical cup load: **50 kg**

Approval number acc. to regulations EKG/ONZ 55.01: E20-55R-01 1078

Foreword

This towbar is designed according to rules of safety traffic regulations. The towing hitch is a safety component and can be install only by qualified personnel. Any alteration or conversion of the towing hitch is prohibited and would lead to cancellation of design certification. Remove insulating compound and underseal from vehicle (if present) in the area of the matting surfaces of the towing hitch. The vehicle manufacturer's specifications regarding trailer load and max. vertical cup load are decisive for driving whereat values for the towing hitch cannot be exceeded.

D-value formula:

$$\frac{\text{Max trailer weight [kg]} \times \text{Max vehicle weight [kg]}}{\text{Max trailer weight [kg]} + \text{Max vehicle weight [kg]}} \times \frac{9,81}{1000} = D \text{ [kN]}$$