

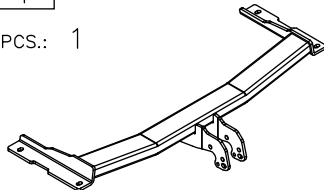

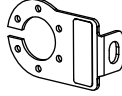

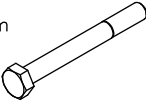

Towbar accessories:

Pos. 1 Main bar  PCS.: 1 Art.no.-BL1X04A	Pos. 3 Socket plate  PCS.: 1 Art.no.-BL1X04A	Pos. 6 Bolt 8,8 B M10x100mm  PCS.: 4
Pos. 2 Tow ball (mounting set)  PCS.: 1 Art.no.-KL1X04A	Pos. 4 Fish-plate 300x50x8mm  PCS.: 2	Pos. 7 Nut 8 B M10  PCS.: 4
	Pos. 5 Distance sleeve ø17,2xø2,35mm  PCS.: 4 L=60mm	Pos. 8 Plain washer ø10,5mm  PCS.: 4
		Pos. 9 Spring washer ø10,2mm  PCS.: 4

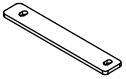

PPUH AUTO-HAK S.J.

Produkcja Zaczepów Kulowych
 Henryk & Zbigniew Nejman
 76-200 SŁUPSK ul. Słoneczna 16K
 tel/fax (059) 8-414-414; 8-414-413
 E-mail: office@autohak.com.pl
 www. autohak.com.pl

Towing hitch (without electrical set)

Class: **A50-X** Cat. no. **X04A**

Designed for:

Manufacturer: **DAEWOO**

Model: **ESPERO**

Type: **4 doors**

produced since 1995 till 1997

Technical data:

D-value: 6,82 kN

maximum trailer weight: **1200 kg**

maximum vertical cup load: **70 kg**

Approval number according to Directive 94/20/EC: **e20*94/20*0540*00**

Foreword

This towbar is designed according to rules of safety traffic regulations. The towing hitch is a safety component and can be install only by qualified personnel. Any alteration or conversion of the towing hitch is prohibited and would lead to cancellation of design certification. Remove insulating compound and underseal from vehicle (if present) in the area of the matting surfaces of the towing hitch.

The vehicle manufacturer's specifications regarding trailer load and max. vertical cup load are decisive for driving, and values for the towing hitch cannot be exceeded.

D-value formula:

$$\frac{\text{Max trailer weight [kg]} \times \text{Max vehicle weight [kg]}}{\text{Max trailer weight [kg]} + \text{Max vehicle weight [kg]}} \times \frac{9,81}{1000} = D \text{ [kN]}$$

FITTING INSTRUCTION

Clamp mark in acc. with		Cables joining
ISO	PN	
1	L	Left directional lights
2	+	Rear fog lights
3	31	Ground
4	R	Right directional lights
5	58R	Right side parking lights
6	54	Stoplights
7	58L	Left side parking lights

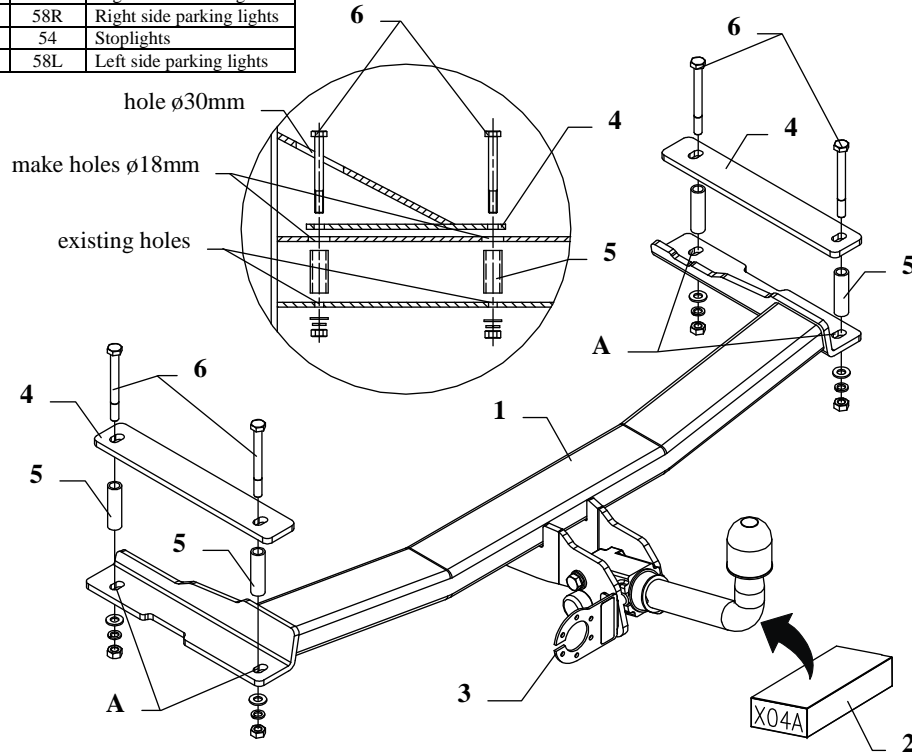

This towbar is designed to assembly in following cars:
DAEWOO ESPERO, 4 doors, produced since 1995 till 1997, catalogue no. **X04A** i and is prepared to tow trailers max total weight **1200 kg** and max vertical load **70 kg**.

From manufacturer

Thank you for buying our product. Their reliability has been confirmed in many tests. Reliability of towbar depends also on correct assembly and right operation. For this reasons we kindly ask to read carefully this instruction and apply to hints.

The towbar should be install in points described by a car producer.

The instruction of the assembly

1. Inside the trunk, on existing ribbings (on the left and right side) apply the attached template and mark point. Then make holes $\varnothing 30\text{mm}$ in ribbing (one hole per side).
2. In the head of the chassis members (in factory-made points) drill holes $\varnothing 18\text{mm}$ (from the side of the trunk).
3. From inside of the trunk (into made holes) put distance sleeves (pos. 5), then apply on it, under the ribbing, fish-plates (pos. 4) from the towbar accessories.
4. Apply the main bar of the towbar – pos. 1 (from the bottom of the car), then through holes of the towbar (pos. A), distance sleeves and fish-plates fix using bolts M10x100mm (pos. 7).
5. Fix body of the automat and place tow-ball according to supplied instruction. Note! Remember to place socket plate (pos. 3) as shown on the drawing 1.
6. Tighten all bolts according to the torque shown in the table.
7. Connect electric wires of 7-poles socket according to the instruction of the car. (Recommend to make at authorized service station).
8. Complete paint layer damaged during installation.

Torque settings for nuts and bolts (8,8):	
M 8 - 25 Nm	M 10 - 55 Nm
M 12 - 85 Nm	M 14 - 135 Nm

NOTE

After install the towbar you should get adequate note in registration book (at authorised service station). The car should be equipped with:

- Indicators
- Tow mirrors

After 1000km of exploitation check all bolts and nuts. The ball of towbar must be always kept clear and conserve with a grease.

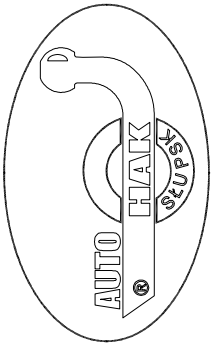

Plattern of car
DAEWOO Espero, 4 drz.
Produced since 1995 till 1997
Catalogue number: X04A

PPUH AUTO-HAK Sp.J.
Henryk & Zbigniew Nejman
ul. Słoneczna 16K
76-200 SŁUPSK, POLAND
tel/fax +48 059 8-414-414;
e-mail: office@autohak.com.pl
www.autohak.com.pl

Cut off marked places

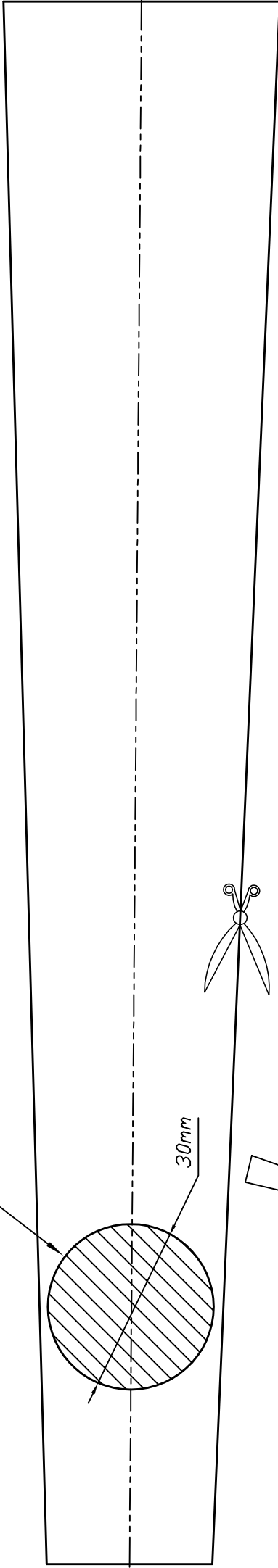

30mm

PATTERN

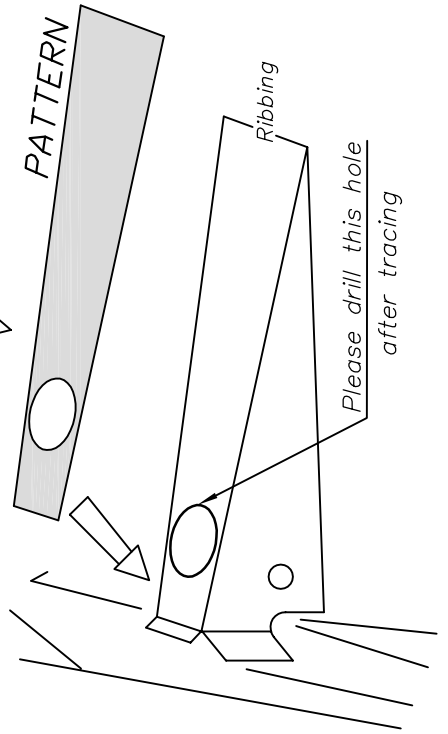

fish plate

Ribbing

Please drill this hole
after tracing