

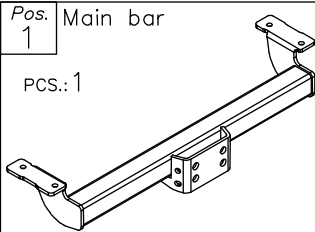







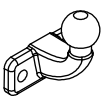

Towing hitch accessories:

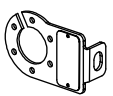
| | | |
|---|---|--|
| Pos. 1 Main bar PCS.: 1 | Pos. 5 Bolt 8,8 B M12x1.25x30mm PCS.: 4 | Pos. 10 Plain washer ø12mm PCS.: 4 |
|  | Pos. 6 Bolt 8,8 B M10x30mm PCS.: 1 | Pos. 11 Plain washer ø10mm PCS.: 1 |
|  | Pos. 2 Tow ball PCS.: 1 | Pos. 12 Spring washer ø16mm PCS.: 2 |
|  | Pos. 7 Nut 8 B M16 PCS.: 2 |  |
| Pos. 3 Socket plate PCS.: 1 | Pos. 8 Nut 8 B M10 PCS.: 1 | Pos. 13 Spring washer ø12mm PCS.: 4 |
|  |  |  |
| Pos. 4 Bolt 8,8 B M16x50mm PCS.: 2 | Pos. 9 Plain washer ø16mm PCS.: 2 | Pos. 14 Spring washer ø10mm PCS.: 1 |
|  |  |  |
| | Pos. 15 Ball cover PCS.: 1 |  |

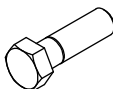

PPUH AUTO-HAK Sp.J.

Produkcja Zaczepów Kulowych
Henryk i Zbigniew Nejman
76-200 SŁUPSK ul. Słoneczna 16K
tel/fax (059) 8-414-414; 8-414-413
E-mail: office@autohak.com.pl
www.autohak.com.pl

Towing hitch (without electrical set)

Class: **A50-X** Cat. no. **W07**

Designed for:

Manufacturer: **SUZUKI**

Model: **VITARA**

Type: **3 door, except V6**

spacing of holes in frame 810mm

produced since 10.1988 till 08.1998

Technical data:

D-value: 7,9 kN

maximum trailer weight: **1500 kg**

maximum vertical cup mass: **75 kg**

Approval number according to Directive 94/20/EC: e20*94/20*0359*00

Foreword

This towing hitch is designed according to rules of safety traffic regulations. The towing hitch is a safety component and can be install only by qualified personnel. Any alteration or conversion of the towing hitch is prohibited and would lead to cancellation of design certification. Remove insulating compound and underseal from vehicle (if present) in the area of the matting surfaces of the towing hitch. The vehicle manufacturer's specifications regarding trailer mass and max. vertical cup mass are decisive for driving whereat values for the towing hitch cannot be exceeded.

D-value formula:

$$\frac{\text{Max trailer weight [kg]} \times \text{Max vehicle weight [kg]}}{\text{Max trailer weight [kg]} + \text{Max vehicle weight [kg]}} \times \frac{9,81}{1000} = D \text{ [kN]}$$

FITTING INSTRUCTION

| Clamp mark in acc. with | | Cables joining |
|-------------------------|-----|---------------------------|
| ISO | PN | |
| 1 | L | Left directional lights |
| 2 | + | Rear fog lights |
| 3 | 31 | Ground |
| 4 | R | Right directional lights |
| 5 | 58R | Right side parking lights |
| 6 | 54 | Stoplights |
| 7 | 58L | Left side parking lights |

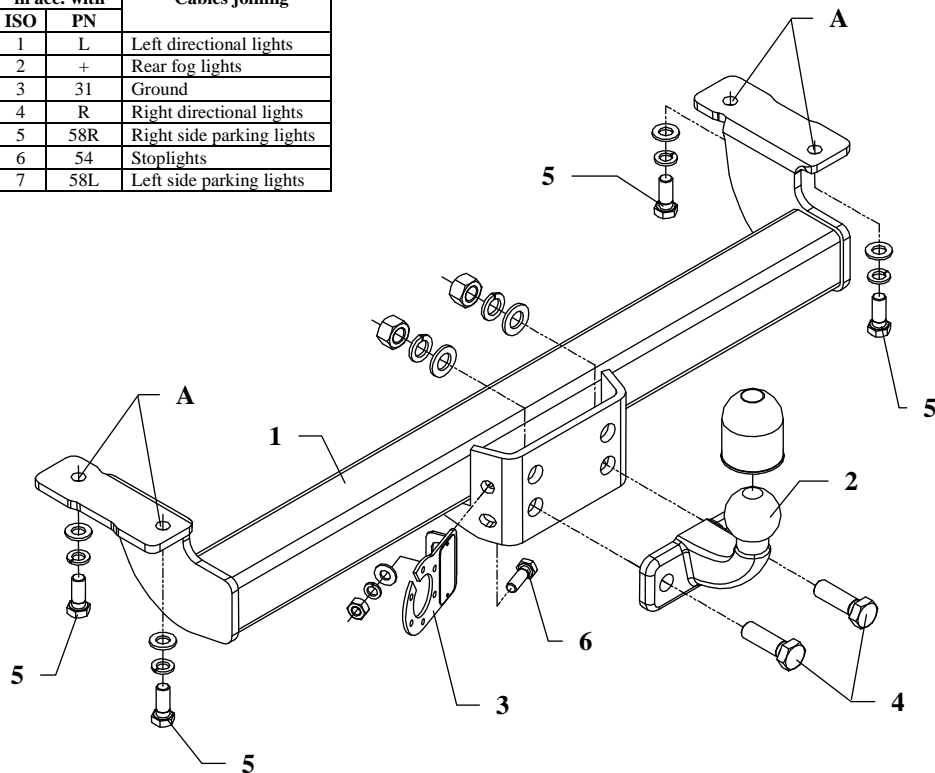

This towing hitch is designed to assembly in following cars:
SUZUKI VITARA, 3 door, except V6, spacing of holes in frame 810mm, produced since 10.1988 till 08.1998, catalogue no. **W07** and is prepared to tow trailers max total weight **1500 kg** and max vertical mass **75 kg**.

From manufacturer

Thank you for buying our product. Their reliability has been confirmed in many tests. Reliability of towing hitch depends also on correct assembly and right operation. For this reasons we kindly ask to read carefully this instruction and apply to hints.

The towing hitch should be install in points described by a car producer.

The instruction of the assembly

1. For the purpose of intallings of the towing hitch one ought to unscrew factory-made towing eye. This towing eye will not be used any more.
2. Apply the main bar of the towing hitch (pos. 1) from the bottom of the car to its frame and trough holes A of the towing hitch and existing in the frame threaded holes fix using bolts M12x1,25x30mm (pos. 5) from the towing hitch accessories.
3. To so installed bar of the towing hitch (pos. 1) fix tow ball (pos. 2) using bolts M16x50mm (pos. 4).
4. Fix the socket plate (pos. 3) as shown on the drawing using bolt M10x30mm (pos. 6).
5. Tighten all bolts according to the torque shown in the table.
6. Connect electric wires of 7-poles socket according to the instruction of the car. (Recommend to make at authorized service station).
7. Complete paint layer damaged during installation.

Torque settings for nuts and bolts (8,8):

| | | |
|--------------------|---------------------|---------------------|
| M6 - 11 Nm | M8 - 25 Nm | M10 - 50 Nm |
| M12 - 87 Nm | M14 - 138 Nm | M16 - 210 Nm |

NOTE

After install the towing hitch you should get adequate note in registration book (at authorised service station). The car should be equipped with:

- Indicators
- Tow mirrors

After 1000km of exploitation check all bolts and nuts. The ball of towing hitch must be always kept clear and conserve with a grease.