

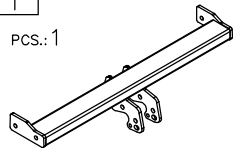

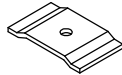







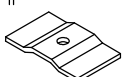



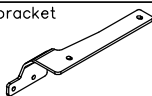

Towing hitch accessories:

Pos. 1 Main bar PCS.: 1 	Pos. 6 Fish-plate I PCS.: 2 	Pos. 12 Nut 8 B M12 PCS.: 2 
	Pos. 7 Fish-plate II PCS.: 2 	Pos. 13 Nut 8 B M10 PCS.: 5 
Pos. 2 Tow ball (mounting set) PCS.: 1 	Pos. 8 Washer ø58xø12x6mm PCS.: 2 	Pos. 14 Washer ø13mm PCS.: 4 
Pos. 3 Socket plate PCS.: 1 	Pos. 9 Distance sleeve I ø17.2x2.35mm L=70mm PCS.: 4 	Pos. 15 Washer ø10,5mm PCS.: 5 
Pos. 4 Right bracket PCS.: 1 	Pos. 10 Bolt 8.8 B M12x35mm PCS.: 4 	Pos. 16 Spring washer ø12,2mm PCS.: 4 
Pos. 5 Left bracket PCS.: 1 	Pos. 11 Bolt 8.8 B M10x100mm PCS.: 5 	Pos. 17 Spring washer ø10,2mm PCS.: 5 
	Pos. 18 Distance sleeve II ø23xø17mm L=70mm PCS.: 4 	

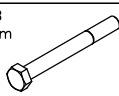

PPUH AUTO-HAK Sp.J.

Produkcja Zaczepów Kulowych
Henryk & Zbigniew Nejman
76-200 SŁUPSK ul. Słoneczna 16K
tel/fax (059) 8-414-414; 8-414-413
E-mail: office@autohak.com.pl
www.autohak.com.pl

Towing hitch (without electrical set)

Class: **A50-X** Cat. no. **W01A**

Designed for:

Manufacturer: **SUZUKI**

Model: **SWIFT**

Type: **4 doors, except 4WD**

produced since 12.1991 till 09.1996

Technical data:

D-value: 5,45 kN

maximum trailer weight: **1000 kg**

maximum vertical cup load: **50 kg**

Approval number according to Directive 94/20/EC: e20*94/20*0059*00

Foreword

This towing hitch is designed according to rules of safety traffic regulations. The towing hitch is a safety component and can be install only by qualified personnel. Any alteration or conversion of the towing hitch is prohibited and would lead to cancellation of design certification. Remove insulating compound and underseal from vehicle (if present) in the area of the matting surfaces of the towing hitch. The vehicle manufacturer's specifications regarding trailer mass and max. vertical cup mass are decisive for driving whereat values for the towing hitch cannot be exceeded.

D-value formula:

$$\frac{\text{Max trailer weight [kg]} \times \text{Max vehicle weight [kg]}}{\text{Max trailer weight [kg]} + \text{Max vehicle weight [kg]}} \times \frac{9,81}{1000} = D \text{ [kN]}$$

FITTING INSTRUCTION

Clamp mark in acc. with		Cables joining
ISO	PN	
1	L	Left directional lights
2	+	Rear fog lights
3	31	Ground
4	R	Right directional lights
5	58R	Right side parking lights
6	54	Stoplights
7	58L	Left side parking lights

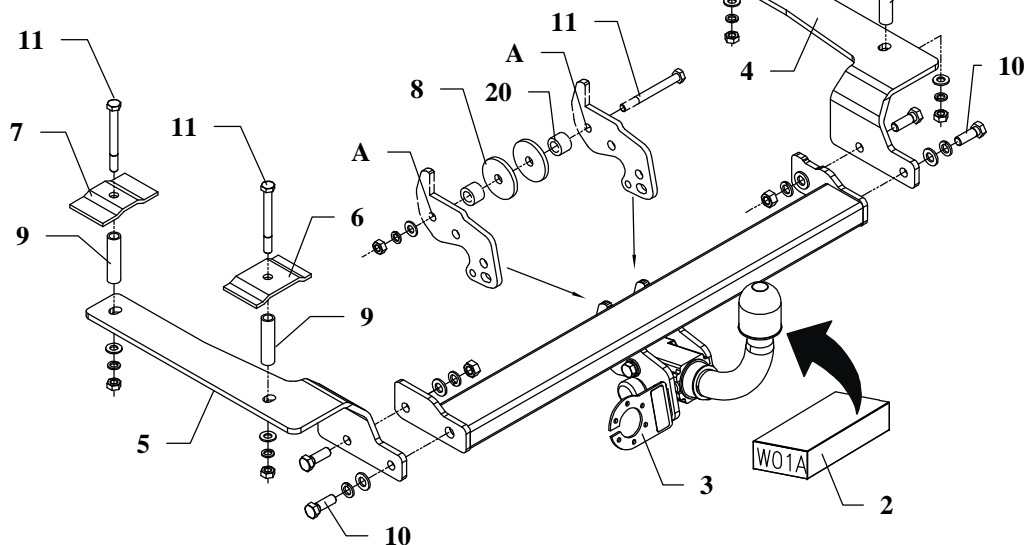

This towing hitch is designed to assembly in following car: **SUZUKI SWIFT, 4 doors, except 4WD**, produced since 12.1991 till 09.1996, catalogue number **W01A** and is prepared to tow trailers max total weight **1000 kg** and max vertical load **50 kg**.

The instruction of the assembly

1. Disassemble the muffler.
2. Take out the fitted carpet from the trunk.
3. Find plastic protruding plugs (pins) on the left and right side in the trunk. Take them out. Raised holes are base holes. Mark second holes as shown on the figure 2. Next drill marked holes straight through using bit $\phi 11\text{mm}$, then enlarge it only from luggage part by bit $\phi 17\text{mm}$.

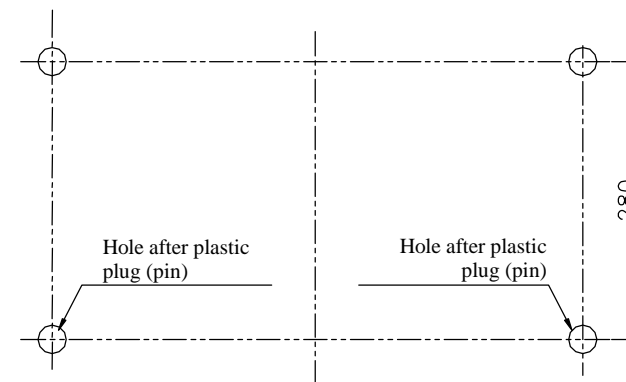

Fig. 2

4. To prepared holes put distance sleeves $\phi 17\text{mm}$, $L=70\text{mm}$ (pos. 9).
5. On holes put fish-plates (pos. 6 and 7) as shown on figure 1, next put bolts $M10 \times 100\text{mm}$ (pos. 11).
6. Underneath the car, to the chassis frame put side brackets (pos. 4 and 5) and fix it loosely.
7. Between installed brackets put main bar of the towing hitch (pos. 1) and fix it loosely using bolts $M12 \times 35\text{mm}$ (pos. 10).
8. Through holes (pos. A) fix with original towing eye using distance sleeves (pos. 20), washers $\phi 58 \times \phi 12 \times 6\text{mm}$ (pos. 8) and bolt $M10 \times 100\text{mm}$ (pos. 11).
9. Fix tight all bolts according to the torque shown in the table.
10. Reassemble the muffler.
11. Fix body of the automat and place tow-ball according to supplied instruction. Note! Remember to place socket plate (pos. 3) as shown on the drawing 1.
12. Connect electric wires of 7-poles socket according to the instruction of the car. (Recommend to make at authorized service station)
13. Complete paint layer damaged during installation.

Torque settings for nuts and bolts (8,8):	
M 8 - 25 Nm	M 10 - 55 Nm
M 12 - 85 Nm	M 14 - 135 Nm

NOTE

After installation of a towing hitch you should get adequate note in registration book (at authorised service station). The car should be equipped with:

- Indicators
- Tow mirrors

After 1000km of exploitation check all bolts and nuts. The ball of towing hitch must be always kept clear and conserve with a grease.