

FITTING INSTRUCTION

Clamp mark in acc. with		Cables joining
ISO	PN	
1	L	Left directional lights
2	+	Rear fog lights
3	31	Ground
4	R	Right directional lights
5	58R	Right side parking lights
6	54	Stoplights
7	58L	Left side parking lights

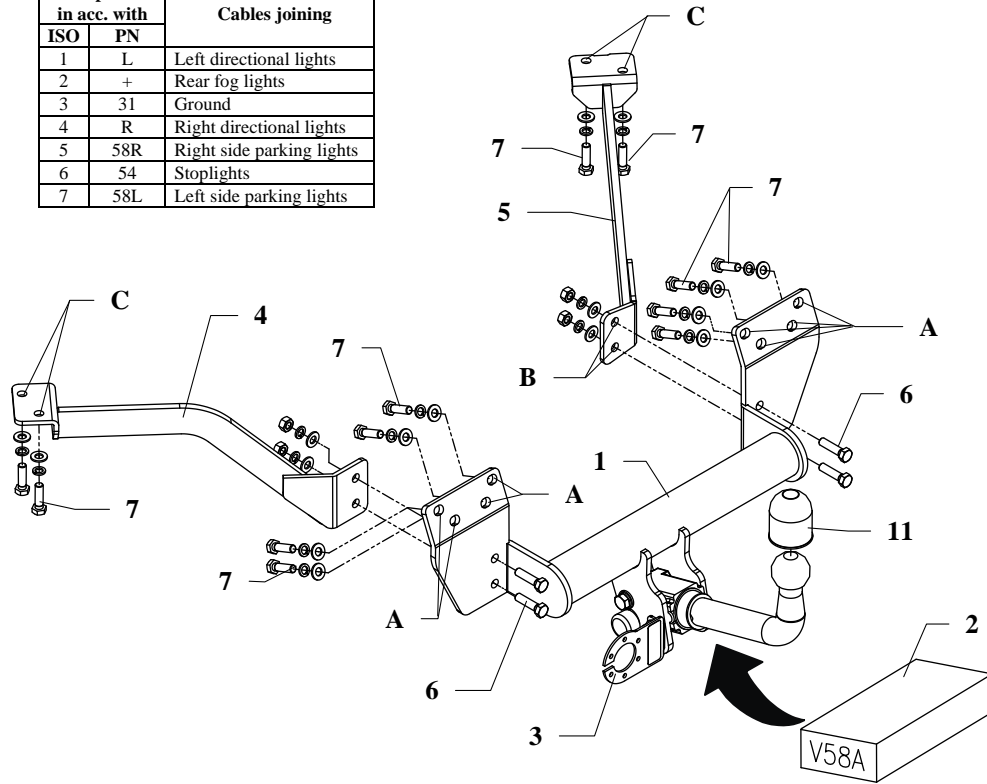

Fig. 1

This towbar is designed to assembly in following cars:
NISSAN VANETTE, delivery VAN (C23 M/C) CARGO produced since 01.1995 till 12.2001, catalogue no. **V58A** and is prepared to tow trailers max total weight **1600 kg** and max vertical load **80 kg**.

From manufacturer

Thank you for buying our product. Their reliability has been confirmed in many tests. Reliability of towbar depends also on correct assembly and right exploit. For this reasons we kindly ask to read carefully this instruction and apply to hints.

The towbar should be install in points described by a car producer.

Fitting instruction

1. Put main bar of towbar (pos. 1) to rear part of the car in this way so holes (pos. A) agree with original threaded holes and screw all using bolts M10x1,25x35mm (pos. 7).
2. Element (pos. 4) put to towbar (left side) in this way, so holes (pos. B) agree with holes in towbar and holes (pos. C) agree with original threaded holes in chassis member and screw using bolts – see drawing.
3. Element (pos. 5) put to towbar (right side) and screw as described in point 2.
4. Tighten all bolts according to the torque shown in the table.
5. Fix body of the automat and place tow-ball according to supplied instruction. Note! Remember to place socket plate (pos. 3) as shown on the drawing 1.
6. Connect electric wires of 7-poles socket according to the instruction of the car. (Recommend to make at authorized service station)
7. Complete the paint coating damaged during installation.

Torque settings for nuts and bolts (8,8):

M 8	25 Nm	M 10	55 Nm
M 12	85 Nm	M 14	135 Nm



NOTE

After install the towbar you should get adequate registration in registration book (at authorised service station).The car should be equipped with:

- Indicators
- Tow mirrors

After 1000km check all bolts and nuts. The ball of towbar must be always kept clear and conserve with a grease.

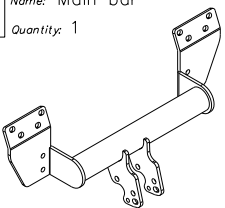
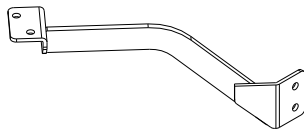
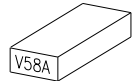
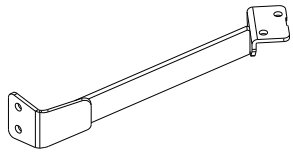
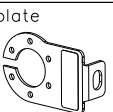
Towbar accessories:

Pos. 1	Name: Main bar Quantity: 1	Pos. 4	Name: Left bracket Quantity: 1	Pos. 6	Name: Bolt 8,8 B Quantity: 4 Dim.: M10x40mm
				Pos. 7	Name: Bolt 8,8 B Quantity: 12 Dim.: M10x1,25x35mm
Pos. 2	Name: Tow ball Quantity: 1	Pos. 5	Name: Right bracket Quantity: 1	Pos. 8	Name: Nut 8 B Quantity: 4 Dim.: M10
				Pos. 9	Name: Plain washer Quantity: 16 Dim.: ø12,5mm
Pos. 3	Name: Socket plate Quantity: 1			Pos. 10	Name: Spring washer Quantity: 16 Dim.: ø10,2mm
					



PPUH AUTO-HAK S.J.

Produkcja Haków Holowniczych
Henryk i Zbigniew Nejman
76-200 SŁUPSK ul. Słoneczna 16K
tel/fax (059) 8-414-414; 8-414-413
E-mail: office@autohak.com.pl
www. autohak.com.pl

Towing hitch (without electrical set)

Class: **A50-X** Cat. no. **V58A**

Designed for:

Manufacturer: **NISSAN**

Model: **VANETTE CARGO**

Type: **delivery VAN (C23 M/C) CARGO**

produced since 01.1995 till 12.2001

Technical data:

D-value: 9,7 kN

maximum trailer weight: **1600 kg**

maximum vertical cup load: **80 kg**

Approval number according to Directive 94/20/EC: **e20*94/20*1070*00**

Foreword

This towbar is design according to rules of safety traffic regulations. The towing hitch is a safety component and must be installed only by qualified personnel. Any alteration or conversion to the towinh hitch is prohibited and would lead to cancellation of design certification. Remove insulating compound and underseal from vehicle (if present) in the area of the matting surfaces of the towing hitch. The vehicle manufacturer's specifications regarding trailer load and max. vertical cup load are decisive for driving, and values for the towing hitch must not be exceeded.

D-value formula:

$$\frac{\text{Max trailer weight [kg]} \times \text{Max vehicle weight [kg]}}{\text{Max trailer weight [kg]} + \text{Max vehicle weight [kg]}} \times \frac{9,81}{1000} = D \text{ [kN]}$$