

## FITTING INSTRUCTION

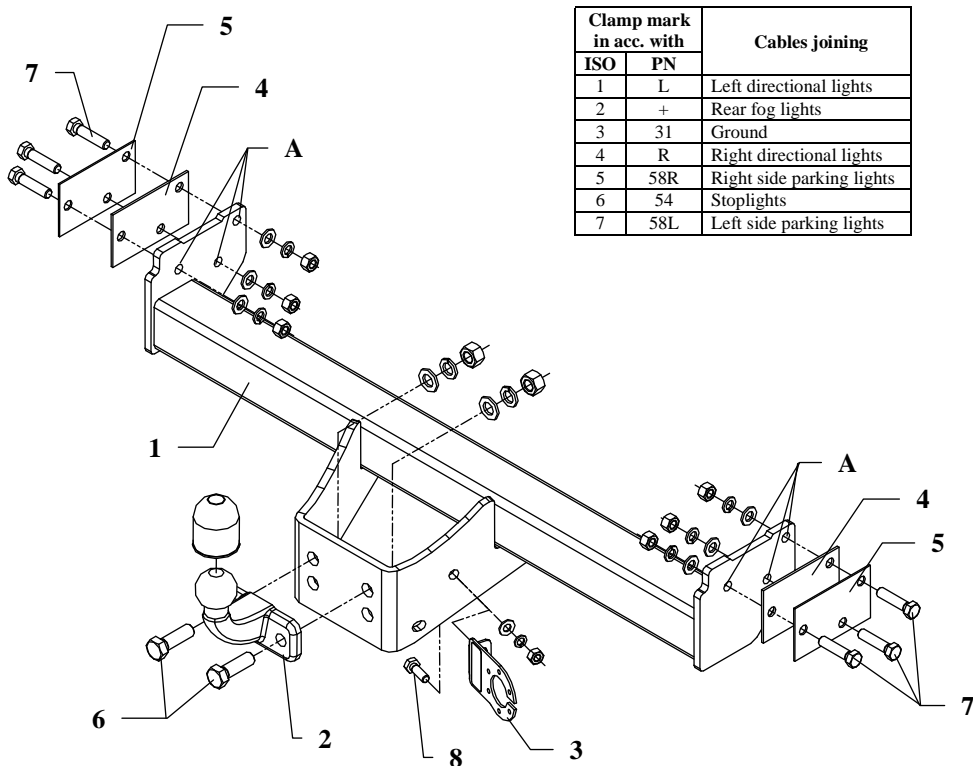

This towing hitch is designed to assembly in following cars:  
**NISSAN TERRANO II, 3/5 doors, (R20)**, produced since 02.1993 till 02.2005, **FORD MAVERICK, 3/5 doors, R20, UDS, UNS**, produced since 06.1993 till 04.2001, catalogue no. **V18** and is prepared to tow trailers max total weight **3000 kg** and max vertical mass **100 kg**.

### *From manufacturer*

Thank you for buying our product. Their reliability has been confirmed in many tests. Reliability of towing hitch depends also on correct assembly and right operation. For this reasons we kindly ask to read carefully this instruction and apply to hints.

*The towing hitch should be install in points described by a car producer.*

## The instruction of the assembly

1. Fix the main bar of the towing hitch (pos. 1) to chassis members through holes A and existing holes in car. Use bolts M12x50mm (pos. 7).
- ATTENTION!** In case when between towing hitch and chassis members are some break use fish-plates (pos. 4 or pos. 5) (different thickness) to level it.
2. Fix tow-ball (pos. 2) using bolts M16x50mm (pos. 6) from accessories.
3. Fix the socket plate (pos. 3) using bolt M10x30mm (pos. 8) as shown on the drawing.
4. Tighten all bolts according to the torque shown in the table.
5. Connect electric wires of 7-poles socket according to the instruction of the car. (Recommend to make at authorized service station).
6. Complete paint layer damaged during installation.

Torque settings for nuts and bolts (8,8):		
<b>M6</b> - 11 Nm	<b>M8</b> - 25 Nm	<b>M10</b> - 50 Nm
<b>M12</b> - 87 Nm	<b>M14</b> - 138 Nm	<b>M16</b> - 210 Nm

### NOTE











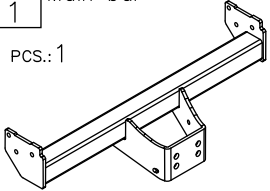
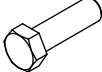

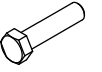

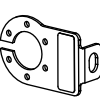

After install the towing hitch you should get adequate note in registration book (at authorised service station). The car should be equipped with:

- Indicators
- Tow mirrors

After 1000km of exploitation check all bolts and nuts. The ball of towing hitch must be always kept clear and conserve with a grease.



**Towing hitch accessories:**

<b>Pos. 1</b> Main bar  PCS.: 1	<b>Pos. 6</b> Bolt 8,8 B M16x50mm  PCS.: 2	<b>Pos. 12</b> Spring washer ø16,3mm  PCS.: 2
	<b>Pos. 7</b> Bolt 8,8 B M12x50mm  PCS.: 6	<b>Pos. 13</b> Spring washer ø12mm  PCS.: 6
<b>Pos. 2</b> Tow ball  pcs.: 1	<b>Pos. 8</b> Bolt 8,8 B M10x30mm  PCS.: 1	<b>Pos. 14</b> Spring washer ø10,2mm  PCS.: 1
<b>Pos. 3</b> Socket plate  pcs.: 1	<b>Pos. 9</b> Plain washer ø17mm  PCS.: 2	<b>Pos. 15</b> Nut 8 B M16  PCS.: 2
<b>Pos. 4</b> Fish-plate I 125x75x3mm  PCS.: 2	<b>Pos. 10</b> Plain washer ø12mm  PCS.: 6	<b>Pos. 16</b> Nut 8 B M12  PCS.: 6
<b>Pos. 5</b> Fish-plate II 125x75x2mm  PCS.: 2	<b>Pos. 11</b> Plain washer ø10,5mm  PCS.: 1	<b>Pos. 17</b> Nut 8 B M10  PCS.: 1
	<b>Pos. 18</b> Ball cover  PCS.: 1	

**Towing hitch (without electrical set)**

Class: **A50-X** Cat. no. **V18**

Designed for:

Manufacturer: **NISSAN**

Model: **TERRANO II**

Type: **3/5 doors, (R20)**

produced since 02.1993 till 02.2005

Manufacturer: **FORD**

Model: **MAVERICK**

Type: **3/5 doors, R20, UDS, UNS**

produced since 06.1993 till 04.2001

Technical data:

**D-value: 13,66 kN**

maximum trailer weight: **3000 kg**

maximum vertical cup mass: **100 kg**

**Approval number acc. to regulations EKG/ONZ 55.01: E20-55R-01 1190**

**Foreword**

This towing hitch is designed according to rules of safety traffic regulations. The towing hitch is a safety component and can be install only by qualified personnel. Any alteration or conversion of the towing hitch is prohibited and would lead to cancellation of design certification. Remove insulating compound and underseal from vehicle (if present) in the area of the matting surfaces of the towing hitch. The vehicle manufacturer's specifications regarding trailer mass and max. vertical cup mass are decisive for driving whereat values for the towing hitch cannot be exceeded.

*D-value formula:*

$$\frac{\text{Max trailer weight [kg]} \times \text{Max vehicle weight [kg]}}{\text{Max trailer weight [kg]} + \text{Max vehicle weight [kg]}} \times \frac{9,81}{1000} = D \text{ [kN]}$$