

FITTING INSTRUCTION

Clamp mark in acc. with		Cables joining
ISO	PN	
1	L	Left directional lights
2	+	Rear fog lights
3	31	Ground
4	R	Right directional lights
5	58R	Right side parking lights
6	54	Stoplights
7	58L	Left side parking lights

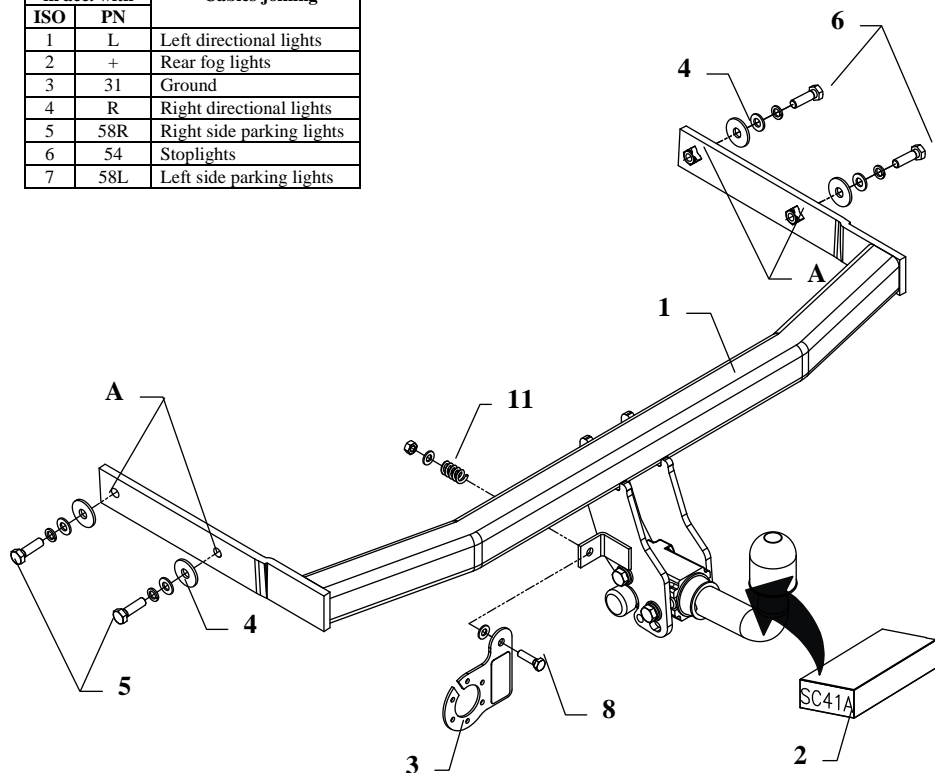

This towing hitch is designed to assembly in following car:
SEAT CORDOBA, 4 doors (6L2), produced since 01.2003, catalogue no.
SC41A and is prepared to tow trailers max total weight **1200kg** and max
 vertical load **50kg**.

From manufacturer

Thank you for buying our product. Their reliability has been confirmed in many tests. Reliability of towing hitch depends also on correct assembly and right operation. For this reasons we kindly ask to read carefully this instruction and apply to hints.

The towing hitch should be install in points described by a car producer.

The instruction of the assembly

1. Disassemble the rear bumper and original metal bumper support (this part is not used any more).
2. Slide the main bar of the towing hitch (pos. 1) to the chassis members (do it such a way holes (pos. A) cover original holes in the chassis members), then fix it using bolts M10x35mm (pos. 5) together with plain washers (pos. 4).
3. Cut the bumper according to the fig. 2 and then reassemble it.

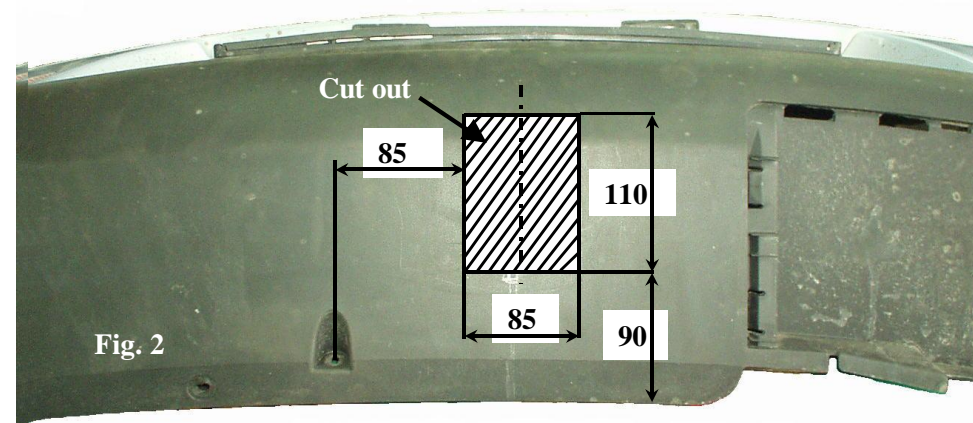

4. Tighten all nuts and bolts according to the torque shown in the table.
5. Fix body of the automat and place tow-ball according to supplied instruction.
6. Fix the socket plate (pos. 3) as shown on the drawing.
7. Connect the electric wires according to the instructions of the car
8. Complete the paint cover of towing hitch (during the mounting paint cover could be destroyed)

Torque settings for nuts and bolts (8,8):

M6 - 11 Nm	M 8 - 25 Nm	M 10 - 50 Nm
M 12 - 87 Nm	M 14 - 138 Nm	M16 - 210 Nm









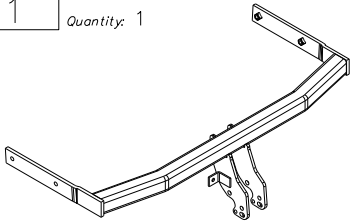

NOTE

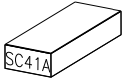
After install the towing hitch you should get adequate note in registration book (at authorised service station).The car should be equipped with:

- Indicators
- Tow mirrors

After 1000km of exploitation check all bolts and nuts. The ball of towing hitch must be always kept clear and conserve with a grease.

Towing hitch accessories:

Pos. 1	Name: Main bar Quantity: 1		Pos. 6	Name: Plain washer Quantity: 4 Dim.: Ø 10,5 mm	
			Pos. 7	Name: Spring washer Quantity: 4 Dim.: Ø 10,2 mm	
Pos. 2	Name: Tow ball Quantity: 1		Pos. 8	Name: Bolt 8,8 B Quantity: 1 Dim.: M8x30mm	
Pos. 3	Name: Socket plate Quantity: 1		Pos. 9	Name: Plain washer Quantity: 2 Dim.: Ø 8,5 mm	
Pos. 4	Name: Washer Quantity: 4 Dim.: Ø35xØ12x3mm		Pos. 10	Name: Nut 8 B Quantity: 1 Dim.: M8	
Pos. 5	Name: Bolt 8,8 B Quantity: 4 Dim.: M10x35mm		Pos. 11	Name: Spring Quantity: 1	



PPUH AUTO-HAK Sp.J.

Produkcja Zaczepów Kulowych
Henryk & Zbigniew Nejman
76-200 SŁUPSK ul. Słoneczna 16K
tel/fax (059) 8-414-414; 8-414-413
E-mail: office@autohak.com.pl
www.autohak.com.pl

Towing hitch (without electrical set)

Class: **A50-X** Cat. no. **SC41A**

Designed for:

Manufacturer: **SEAT**

Model: **CORDOBA**

Type: **4 doors (6L2)**

produced since 01.2003

Technical data:

D-value: 6,96 kN

maximum trailer weight: **1200 kg**

maximum vertical cup load: **50 kg**

Approval number according to Directive 94/20/EC: e20*94/20*1128*00

Foreword

This towing hitch is designed according to rules of safety traffic regulations. The towing hitch is a safety component and can be install only by qualified personnel. Any alteration or conversion of the towing hitch is prohibited and would lead to cancellation of design certification. Remove insulating compound and underseal from vehicle (if present) in the area of the matting surfaces of the towing hitch.

The vehicle manufacturer's specifications regarding trailer load and max. vertical cup load are decisive for driving, and values for the towing hitch cannot be exceeded.

D-value formula:

$$\frac{\text{Max trailer weight [kg]} \times \text{Max vehicle weight [kg]}}{\text{Max trailer weight [kg]} + \text{Max vehicle weight [kg]}} \times \frac{9,81}{1000} = D \text{ [kN]}$$