

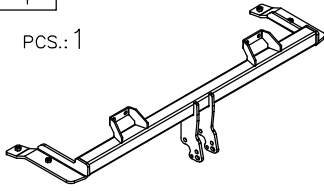

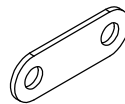





Towbar accessories:

Pos. 1	Main bar 	PCS.: 1
Pos. 4	Fish-plate 78x26mm 	PCS.: 2
Pos. 5	Washer ø25xø12x3mm 	PCS.: 4
Pos. 8	Nut 8 B M10 	PCS.: 4
Pos. 9	Washer ø10,5mm 	PCS.: 4
Pos. 2	Tow ball (mounting set) 	PCS.: 1
Pos. 6	Bolt 8.8 B M10x35mm 	PCS.: 4
Pos. 10	Spring washer ø10,2mm 	PCS.: 8
Pos. 3	Socket plate 	PCS.: 1
Pos. 7	Bolt 8.8 B M10x30mm 	PCS.: 4

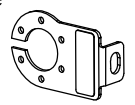

PPUH AUTO-HAK Sp.J.

Produkcja Zaczepów Kulowych
Henryk & Zbigniew Nejman
76-200 SŁUPSK ul. Słoneczna 16K
tel/fax (059) 8-414-414; 8-414-413
E-mail: office@autohak.com.pl
www.autohak.com.pl

Towing hitch (without electrical set)

Class: **A50-X** Cat. no. **SC27A**

Designed for:

Manufacturer: **SEAT**

Model: **TOLEDO**

Type: **5 doors (1L)**

produced since 11.1995 till 10.1998

Technical data:

maximum **D**-value: **7,45 kN**

maximum trailer weight: **1450 kg**

maximum vertical cup load: **80 kg**

Approval number according to Directive 94/20/EC: **e20*94/20*1132*00**

Foreword

This towing hitch is designed according to rules of safety traffic regulations. The towing hitch is a safety component and can be installed only by qualified personnel. Any alteration or conversion of the towing hitch is prohibited and would lead to cancellation of design certification. Remove insulating compound and underseal from vehicle (if present) in the area of the mating surfaces of the towing hitch. The vehicle manufacturer's specifications regarding trailer mass and max. vertical cup mass are decisive for driving whereat values for the towing hitch cannot be exceeded.

D-value formula:

$$\frac{\text{Max trailer weight [kg]} \times \text{Max vehicle weight [kg]}}{\text{Max trailer weight [kg]} + \text{Max vehicle weight [kg]}} \times \frac{9,81}{1000} = D \text{ [kN]}$$

FITTING INSTRUCTION

Clamp mark in acc. with		Cables joining
ISO	PN	
1	L	Left directional lights
2	+	Rear fog lights
3	31	Ground
4	R	Right directional lights
5	58R	Right side parking lights
6	54	Stoplights
7	58L	Left side parking lights

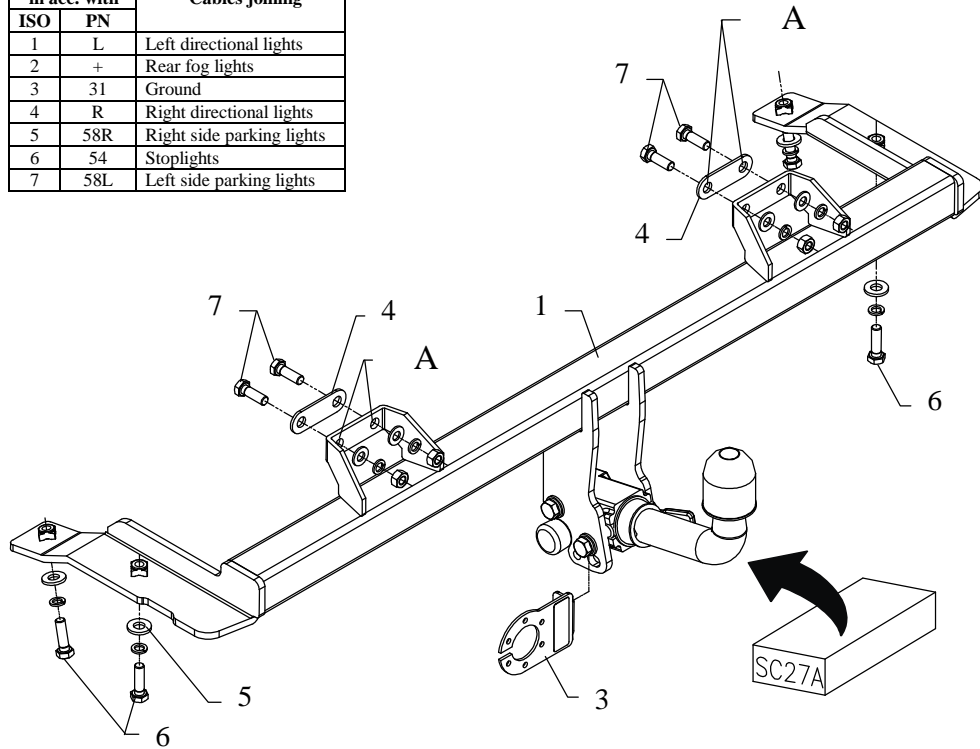

This towing hitch is designed to assembly in following cars:
SEAT TOLEDO, 5 doors (1L), produced since 11.1995 till 10.1998,
 catalogue no. **SC27A** and is prepared to tow trailers max total weight
1450 kg and max vertical load **80 kg**.

From manufacturer

Thank you for buying our product. Their reliability has been confirmed in many tests. Reliability of towbar depends also on correct assembly and right operation. For this reasons we kindly ask to read carefully this instruction and apply to hints.

The towbar should be install in points described by a car producer.

Fitting instructions

1. Disassemble the bumper and next unscrew handles (not used any more).
2. In lower part of bumper cut his fragment 95x80mm (use template).
3. Slip the main bar of towbar (pos. 1) to chassis members and next through original holes (from below the car) skewer using bolts M10x35mm (pos. 6) from towbar accessories (use round washers $\varnothing 25 \times 12 \times 3$ mm – pos. 5).
4. Through holes (pos. A) drill holes using bit $\varnothing 10,5$ mm and next skewer using bolts M10x30mm (pos. 7) – use washers (pos. 4).
5. Assemble the bumper .
6. Fix body of the automat and place tow-ball according to supplied instruction. Note! Remember to place socket plate (pos. 3) as shown on the drawing 1.
7. Tighten all bolts according to the torque shown in the table.
8. Connect electric wires of 7-poles socket according to the instruction of the car. (Recommend to make at authorized service station).
9. Complete the paint coating damaged during installation.

Torque settings for nuts and bolts (8,8):

M6 - 11 Nm	M 8 - 25 Nm	M 10 - 50 Nm
M 12 - 87 Nm	M 14 - 138 Nm	M16 - 210 Nm

NOTE

After installation of a towing hitch you should get adequate note in registration book (at authorised service station). The car should be equipped with:

- Indicators
- Tow mirrors

After 1000km of exploitation check all bolts and nuts. The ball of towing hitch must be always kept clear and conserve with a grease.