

FITTING INSTRUCTION

Clamp mark in acc. with		Cables joining
ISO	PN	
1	L	Left directional lights
2	+	Rear fog lights
3	31	Ground
4	R	Right directional lights
5	58R	Right side parking lights
6	54	Stoplights
7	58L	Left side parking lights

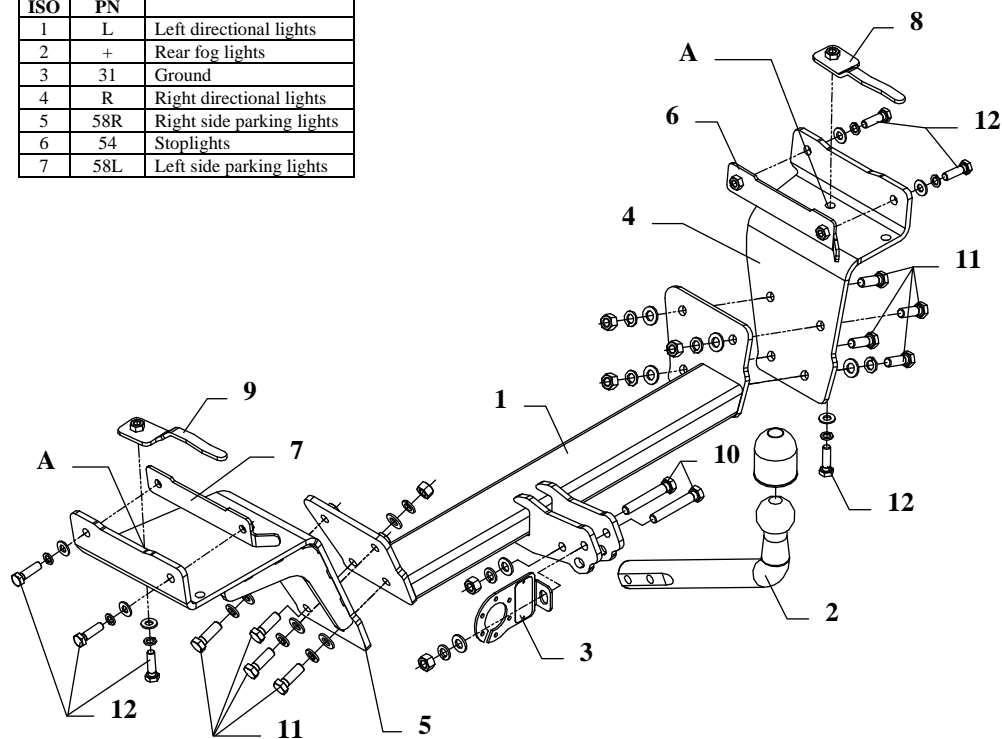

This towing hitch is designed to assembly in following cars: **FIAT STILO 3/5 doors, except Abarth**, produced since 10.2001 till 03.2007, catalogue no. **R30** and is prepared to tow trailers max total weight **1400 kg** and max vertical load **60 kg**.

From manufacturer

Thank you for buying our product. Their reliability has been confirmed in many tests. Reliability of towing hitch depends also on correct assembly and right operation. For this reasons we kindly ask to read carefully this instruction and apply to hints.

The towing hitch should be install in points described by a car producer. Before installation the towing hitch please look at the page 264 of the car instruction.

Fitting instructions

1. Remove the rear bumper.
2. Outside the left and right chassises drill two holes $\varnothing 11\text{mm}$ in each ones (see fig. below).

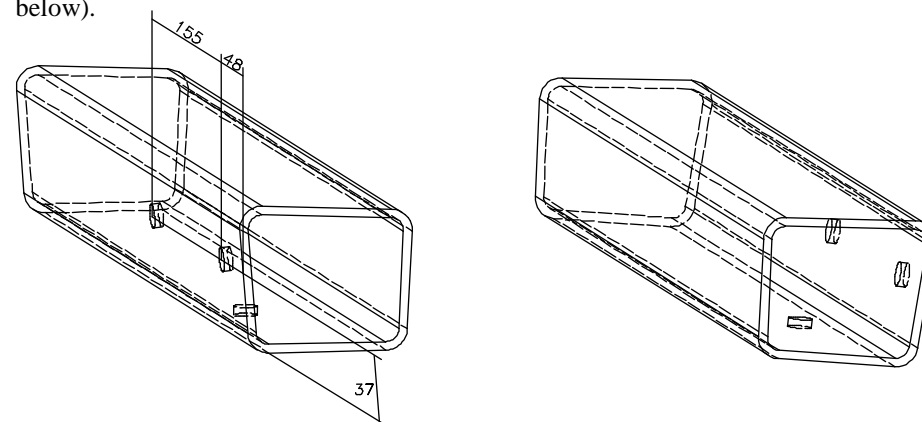

3. Position the bracket (pos. 5 – the left side) and brakcet (pos. 4 – the right side) at the earlier drilled holes and fix with the side fish-plates – pos. 6 and 7 (put it earlier into the chassis). Then through the holes (pos. A) of the brackets (pos. 4 and 5) drill holes $\varnothing 11\text{mm}$ and fix with the fish-plates cpl. – pos. 8 and 9 (put it earlier into the chassis also).
4. Position the main bar of the towing hitch (pos. 1) and fix with bolts M12x35mm (pos. 11).
5. Mount the bumper.
6. Position the ball of towing hitch (pos. 2) with socket plate (pos. 3) and fix with M12x75mm (pos. 10) bolts from the towing hitch accessories.
7. Tighten all nuts and bolts according the torque shown in the table.
8. Connect the electric wires according to the instructions of the car.
9. Complete the paint cover of towing hitch (during the mounting paint cover could be destroyed).

Torque settings for nuts and bolts (8,8):	
M 8 - 25 Nm	M 10 - 55 Nm
M 12 - 85 Nm	M 14 - 135 Nm











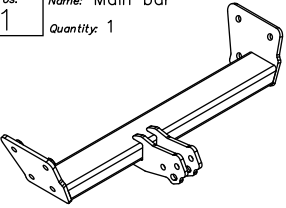
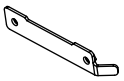
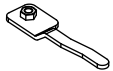

NOTE

After install the towing hitch you should get adequate note in registration book (at authorised service station).The car should be equipped with:

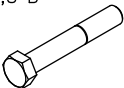
- Indicators
- Tow mirrors

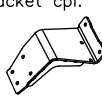
After 1000km check all bolts and nuts. The ball of towing hitch must be always kept clear and conserve with a grease.

Towing hitch accessories:

Pos. 1 Name: Main bar Quantity: 1	Pos. 6 Name: Right side fish-plate cpl. Quantity: 1	Pos. 12 Name: Bolt 8,8 B Quantity: 6 Dim.: M10x35mm
	Pos. 7 Name: Left side fish-plate cpl. Quantity: 1	Pos. 13 Name: Nut 8 B Quantity: 6 Dim.: M12
	Pos. 8 Name: Right fish-plate cpl. Quantity: 1	Pos. 14 Name: Plain washer Quantity: 10 Dim.: Ø 13 mm
Pos. 2 Name: Tow ball Quantity: 1		
Pos. 3 Name: Socket plate Quantity: 1	Pos. 9 Name: Left fish-plate cpl. Quantity: 1	Pos. 15 Name: Plain washer Quantity: 6 Dim.: Ø 10,5 mm
		
Pos. 4 Name: Right bracket Quantity: 1	Pos. 10 Name: Bolt 8,8 B Quantity: 2 Dim.: M12x75mm	Pos. 16 Name: Spring washer Quantity: 10 Dim.: Ø 12,2 mm
		
Pos. 5 Name: Left bracket cpl. Quantity: 1	Pos. 11 Name: Bolt 8,8 B Quantity: 8 Dim.: M12x35mm	Pos. 17 Name: Spring washer Quantity: 6 Dim.: Ø 10,2 mm
		
	Pos. 18 Name: Ball cover Quantity: 1	



PPUH AUTO-HAK S. J.

Produkcja Haków Holowniczych
Henryk & Zbigniew Nejman
76-200 SŁUPSK ul. Słoneczna 16K
tel/fax (059) 8-414-414; 8-414-413
E-mail: office@autohak.com.pl
www.autohak.com.pl

Towing hitch (without electrical set)

Class: **A50-X** Cat. no. **R30**

Designed for:

Manufacturer: **FIAT**

Model: **STILO**

Type: **3/5 doors, except Abarth**

produced since 10.2001 till 03.2007

Technical data:

D-value: 7,73 kN

maximum trailer weight: **1400 kg**

maximum vertical cup load: **60 kg**

Approval number acc. to regulations EKG/ONZ 55.01: E20-55R-01 0776

Foreword

This towing hitch is designed according to rules of safety traffic regulations. The towing hitch is a safety component and can be install only by qualified personnel. Any alteration or conversion of the towing hitch is prohibited and would lead to cancellation of design certification. Remove insulating compound and underseal from vehicle (if present) in the area of the matting surfaces of the towing hitch. The vehicle manufacturer's specifications regarding trailer load and max. vertical cup load are decisive for driving whereat values for the towing hitch cannot be exceeded.

D-value formula:

$$\frac{\text{Max trailer weight [kg]} \times \text{Max vehicle weight [kg]}}{\text{Max trailer weight [kg]} + \text{Max vehicle weight [kg]}} \times \frac{9,81}{1000} = D \text{ [kN]}$$