

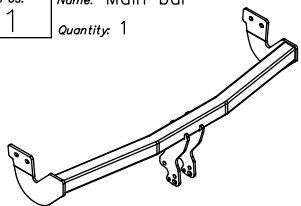

## Towbar accessories:

Pos. 1	Name: Main bar Quantity: 1	Pos. 4	Name: Bolt 8,8 B Quantity: 4 Dim.: M10x35mm	Pos. 8	Name: Bolt 8,8 B Quantity: 1 Dim.: M8x45mm
		Pos. 5	Name: Plain washer Quantity: 4 Dim.: Ø 10,5 mm	Pos. 9	Name: Plain washer Quantity: 2 Dim.: Ø 8,5 mm
		Pos. 6	Name: Spring washer Quantity: 4 Dim.: Ø 10,2 mm	Pos. 10	Name: Nut 8 B Quantity: 1 Dim.: M8
Pos. 3	Name: Socket plate Quantity: 1	Pos. 7	Name: Ball cover Quantity: 1	Pos. 11	Name: Spring Quantity: 1
					

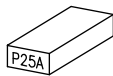
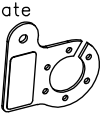

## PPUH AUTO-HAK Sp.J.

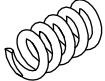
Produkcja Zaczepów Kulowych  
Henryk & Zbigniew Nejman  
76-200 SŁUPSK ul. Słoneczna 16K  
tel/fax (059) 8-414-414; 8-414-413  
E-mail: [office@autohak.com.pl](mailto:office@autohak.com.pl)  
[www.autohak.com.pl](http://www.autohak.com.pl)

### Towing hitch (without electrical set)

Class: **A50-X** Cat. no. **P25A**

Designed for:

Manufacturer: **CITROEN**

Model: **C3, 5doors, except Plurier/X-TR**

produced since 05.2002 till 09.2005

and produced since 10.2005 till 12.2009

Technical data:

**D-value: 6,6 kN**

maximum trailer weight: **1176 kg**

maximum vertical cup load: **50 kg**

**Approval number acc. to regulations EKG/ONZ 55.01: E20-55R-01 4194**

### Foreword

This towing hitch is designed according to rules of safety traffic regulations. The towing hitch is a safety component and can be install only by qualified personnel. Any alteration or conversion of the towing hitch is prohibited and would lead to cancellation of design certification. Remove insulating compound and underseal from vehicle (if present) in the areas of the matting surfaces of the towing hitch.

The vehicle manufacturer's specifications regarding trailer load and max. vertical cup mass are decisive for driving whereat values for the towing hitch cannot be exceeded.

*D-value formula:*

$$\frac{\text{Max trailer weight [kg]} \times \text{Max vehicle weight [kg]}}{\text{Max trailer weight [kg]} + \text{Max vehicle weight [kg]}} \times \frac{9,81}{1000} = D \text{ [kN]}$$

## FITTING INSTRUCTION

Clamp mark in acc. with		Cables joining
ISO	PN	
1	L	Left directional lights
2	+	Rear fog lights
3	31	Ground
4	R	Right directional lights
5	58R	Right side parking lights
6	54	Stoplights
7	58L	Left side parking lights

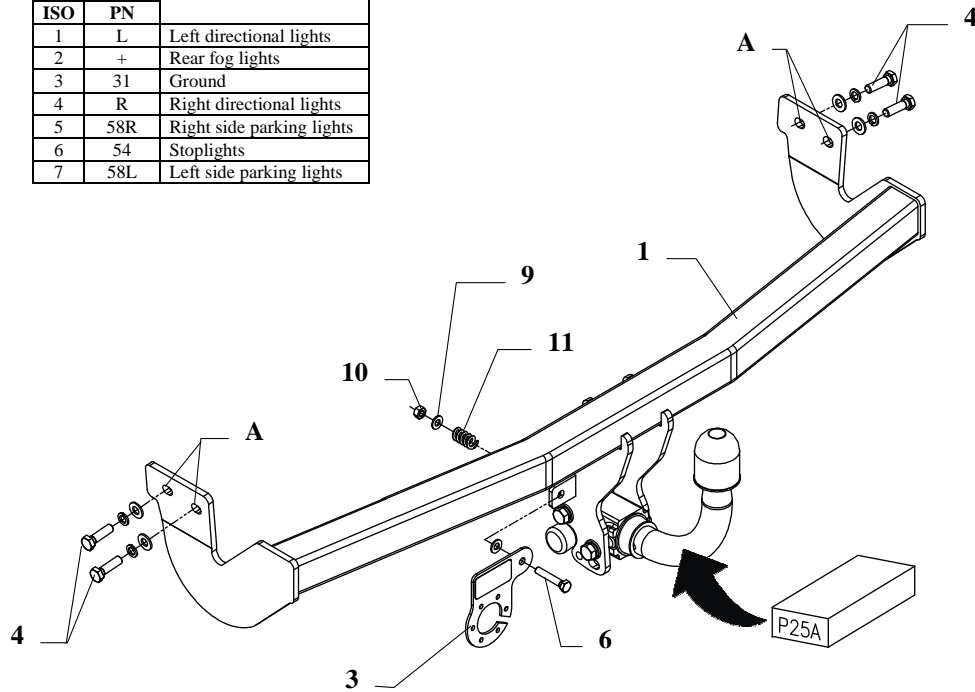

This towbar is designed to assembly in following cars:  
**CITROEN C3, 5 doors, except Plurier/X-TR** produced since 05.2002 till 09.2005, and produced since 10.2005 till 12.2009., catalogue no. **P25A** and is prepared to tow trailers max total weight **1176 kg** and max vertical load **50 kg**.

### *From manufacturer*

Thank you for buying our product. Their reliability has been confirmed in many tests. Reliability of towbar depends also on correct assembly and right operation. For this reasons we kindly ask to read carefully this instruction and apply to hints.

*The towbar should be install in points described by a car producer.*

## The instruction of the assembly

1. Disassemble the bumper.
2. Dismount the metal support- not used any more.
3. Find the original holes under the conservation layer at the chassis member side (these holes are cover with the special assembly line - tear it off).
4. Position the bar of towbar (pos. 1) - do it in such a way that the holes (pos. A) cover just prepared holes and fix it using M10x35mm bolts (pos. 4).
5. Reinstall the bumper.
6. Fix body of the automat according to supplied instruction.
7. Fix the socket plate (pos. 3) as shown on the drawing.
8. Tighten all nuts and bolts according to the torque shown in the table.
9. Connect to the electric wires according to the instructions of the car.
10. Complete the paint cover of towbar (during the mounting paint cover could be destroyed).

### Torque settings for nuts and bolts (8,8):

<b>M6</b> - 11 Nm	<b>M8</b> - 25 Nm	<b>M10</b> - 50 Nm
<b>M12</b> - 87 Nm	<b>M14</b> - 138 Nm	<b>M16</b> - 210 Nm

## NOTE

After install the towbar you should get adequate note in registration book (at authorised service station).The car should be equipped with:

- Indicators
- Tow mirrors

After 1000km of exploitation check all bolts and nuts. The ball of towbar must be always kept clear and conserve with a grease.