

FITTING INSTRUCTION

Clamp mark in acc. with		Cables joining
ISO	PN	
1	L	Left directional lights
2	+	Rear fog lights
3	31	Ground
4	R	Right directional lights
5	58R	Right side parking lights
6	54	Stoptlights
7	58L	Left side parking lights

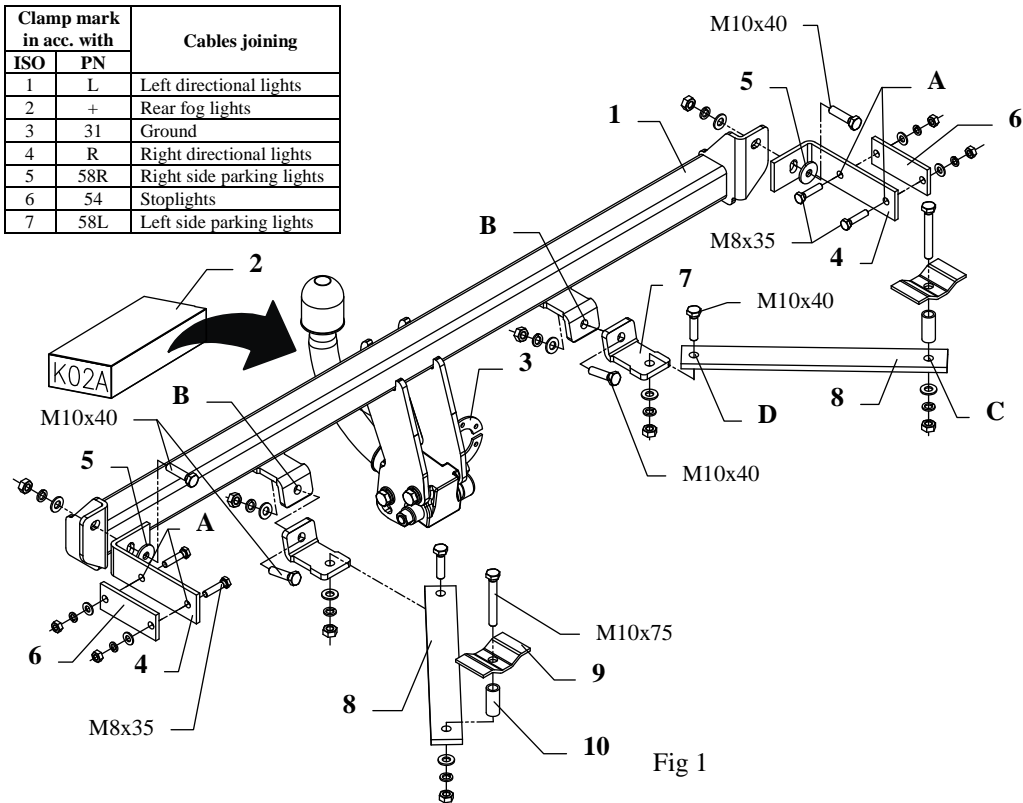

Fig 1

his towbar is designed to assembly in following cars:
VOLKSWAGEN POLO, 3 doors, ESTATE-FOX, produced since 09.1990 till 08.1994, catalogue no. **K02A** and is prepared to tow trailers max total weight **1000 kg** and max vertical load **50 kg**.

From manufacturer

Thank you for buying our product. Their reliability has been confirmed in many tests. Reliability of towbar depends also on correct assembly and right operation. For this reasons we kindly ask to read carefully this instruction and apply to hints.

The towbar should be install in points described by a car producer.

The instruction of the assembly

1. Disassemble the bumper.
2. On the back piece are clearly embossed points which one ought to drill with the bit $\phi 11\text{mm}$.
3. Apply the main bar of the towbar (pos. 1) on bored holes and fix using bolts M10x40mm (pos. 12) through brackets (pos. 4), which one ought to place inside the trunk (on the right and left side). Use washers $\phi 30 \times \phi 10,5 \times 2,5\text{mm}$ (pos. 5).
4. Through holes (pos. A) of brackets (pos. 4) drill holes $\phi 9\text{mm}$ and then fix using bolts M8x35mm (pos. 13) through plate (pos. 6).
5. Through holes (pos. B) of the towbar drill (in the back piece) holes $\phi 11\text{mm}$ and fix with bolts M10x40mm (pos. 12) through angle brackets (pos. 7), which one ought to place from the internal side of the back piece, as showed on the fig. 1.
6. In the chassis member are holes $\phi 11\text{mm}$ (from the bottom of the car by piece from the right and left side), which one ought to drill throughly with the bit $\phi 11\text{mm}$. Then, in part trunk, drill on the diameter $\phi 17\text{mm}$. Into so prepared holes put distance sleeves L=39mm (pos. 10), apply fish-plates (pos. 9) and put bolts M10x75mm (pos. 11), as showed on the fig. 1.
7. So prepared elements of the towbar fix with jibs (pos. 8) in marked points (pos. C and D).
8. Install the bumper after cut out of its fragment 80x150mm, as showed on the fig. 2.

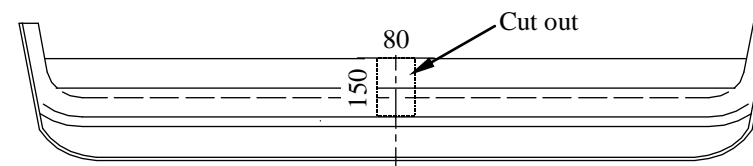

Fig. 2

9. Fix body of the automat and place tow-ball according to supplied instruction. Note! Remember to place socket plate (pos. 3) as shown on the drawing 1.
10. Connect electric wires of 7-poles socket according to the instruction of the car. (Recommend to make at authorized service station).
11. Complete paint layer damaged during installation.

Torque settings for nuts and bolts (8,8):

M6 - 11 Nm	M8 - 25 Nm	M10 - 50 Nm
M12 - 87 Nm	M14 - 138 Nm	M16 - 210 Nm











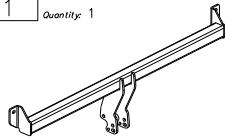

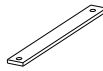



NOTE

After install the towbar you should get adequate note in registration book (at authorised service station).The car should be equipped with:

- Indicators
- Tow mirrors

After 1000km of exploitation check all bolts and nuts. The ball of towbar must be always kept clear and conserve with a grease.

Towbar accessories:

Pos. 1 Name: Main bar Quantity: 1	Pos. 6 Name: Plate Quantity: 2	Pos. 12 Name: Bolt 8,8 B Quantity: 6 Dim.: M10x40mm	Pos. 18 Name: Spring washer Quantity: 8 Dim.: Ø 10,2 mm
	Pos. 7 Name: Angle bracket Quantity: 2	Pos. 13 Name: Bolt 8,8 B Quantity: 4 Dim.: M8x35mm	Pos. 19 Name: Spring washer Quantity: 4 Dim.: Ø 8,2 mm
Pos. 2 Name: Tow ball Quantity: 1	Pos. 8 Name: Jib Quantity: 2	Pos. 14 Name: Nut 8 B Quantity: 8 Dim.: M10	Pos. 20 Name: Ball cover Quantity: 1
			
Pos. 3 Name: Socket plate Quantity: 1	Pos. 9 Name: Washer Quantity: 2	Pos. 15 Name: Nut 8 B Quantity: 4 Dim.: M8	
			
Pos. 4 Name: Bracket Quantity: 2	Pos. 10 Name: Distance sleeve Quantity: 2 Dim.: Ø17.2x2.35mm L=39mm	Pos. 16 Name: Plain washer Quantity: 8 Dim.: Ø 10,5 mm	
			
Pos. 5 Name: Washer Quantity: 2 Dim.: Ø30xØ10,5x2,5mm	Pos. 11 Name: Bolt 8,8 B Quantity: 2 Dim.: M10x75mm	Pos. 17 Name: Plain washer Quantity: 4 Dim.: Ø 8,5 mm	
			



PPUH AUTO-HAK S.J.

Produkcja Zaczepów Kulowych
Henryk & Zbigniew Nejman
76-200 SŁUPSK ul. Słoneczna 16K
tel/fax (059) 8-414-414; 8-414-413
E-mail: office@autohak.com.pl
www.autohak.com.pl

Towing hitch (without electrical set)

Class: **A50-X** Cat. no. **K02A**

Designed for:

Manufacturer: **VOLKSWAGEN**

Model: **POLO**

Type: **3 doors, ESTATE-FOX**

produced since 09.1990 till 08.1994

Technical data:

D-value: 5,54 kN

maximum trailer weight: **1000 kg**

maximum vertical cup load: **50 kg**

Approval number according to Directive 94/20/EC: **e20*94/20*1343*00**

Foreword

This towbar is designed according to rules of safety traffic regulations. The towing hitch is a safety component and can be install only by qualified personnel. Any alteration or conversion of the towing hitch is prohibited and would lead to cancellation of design certification. Remove insulating compound and underseal from vehicle (if present) in the area of the matting surfaces of the towing hitch. The vehicle manufacturer's specifications regarding trailer load and max. vertical cup load are decisive for driving whereat values for the towing hitch cannot be exceeded.

D-value formula:

$$\frac{\text{Max trailer weight [kg]} \times \text{Max vehicle weight [kg]}}{\text{Max trailer weight [kg]} + \text{Max vehicle weight [kg]}} \times \frac{9,81}{1000} = D \text{ [kN]}$$