

FITTING INSTRUCTION

Clamp mark in acc. with		Cables joining
ISO	PN	
1	L	Left directional lights
2	+	Rear fog lights
3	31	Ground
4	R	Right directional lights
5	58R	Right side parking lights
6	54	Stoplights
7	58L	Left side parking lights

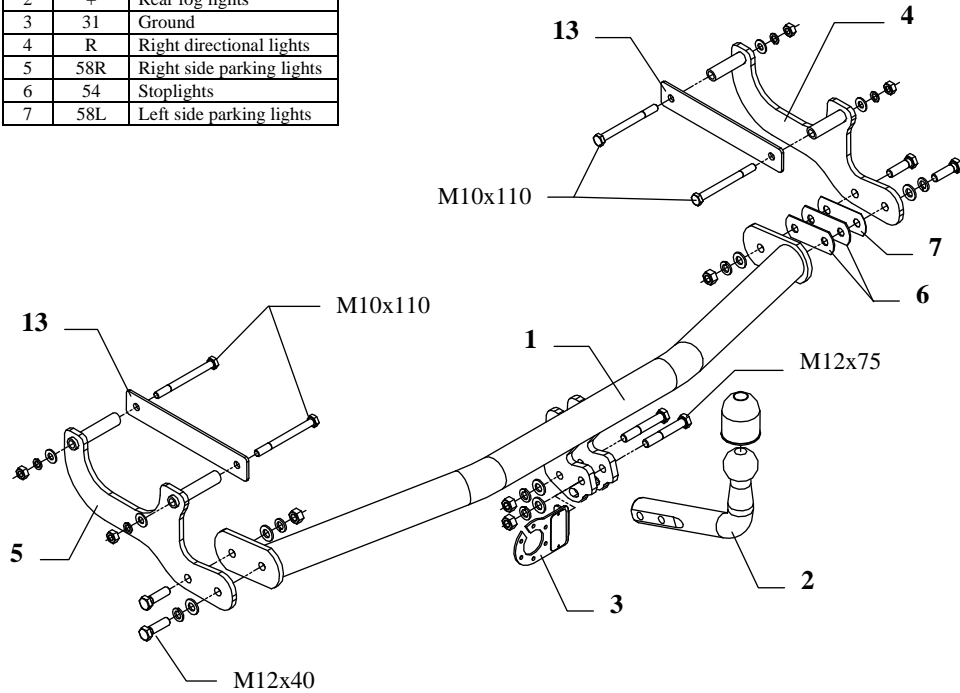

This towing hitch is designed to assembly in following cars:
RENAULT MODUS, 5 doors, VAN, produced since 10.2004 till 01.2008,
 catalogue no. **G48** and is prepared to tow trailers max total weight **900 kg**
 and max vertical load **75 kg**.

From manufacturer

Thank you for buying our product. Their reliability has been confirmed in many tests. Reliability of towing hitch depends also on correct assembly and right operation. For this reasons we kindly ask to read carefully this instruction and apply to hints.

The towing hitch should be install in points described by a car producer.

The instruction of the assembly

1. You can install our towing hitch without bumper disassembly, but twist off all fastening bolts underneath.
2. In lower part of the bumper cut out fragment according to figure 2.
3. Disassemble thermal shield over muffler.
4. From outsides of the chassis members are original holes under technical plaster. Remove plaster and uncover original holes. On this holes put fish-plates pos. 13 and through holes put bolts M10x110mm (pos. 10)
5. From inside put side brackets (pos. 4 and 5) on protruding bolt and fix loosely.
6. Between mounted brackets put main bar of the towing hitch (pos. 1) and fix using bolts M12x40mm (pos. 9), use distance fish-plates (pos. 6 and 7)
7. Fix tow-ball (pos. 2) and socket plate (pos. 3) by bolts M12x75mm (pos. 8) from equipment.
8. Fix tight all bolts according to the torque shown in the table.
9. Connect electric wires of 7-poles socket according to the instruction of the car. (Recommend to make at authorized service station)
10. Complete paint layer damaged during installation.

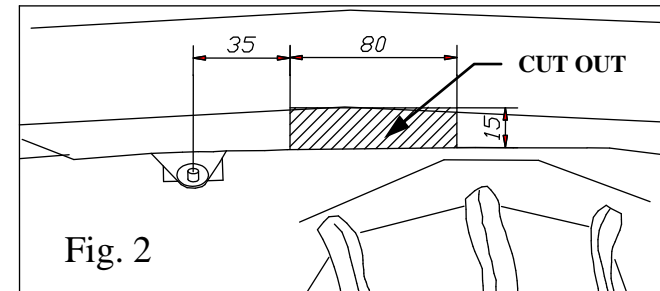

Fig. 2

Torque settings for nuts and bolts (8,8):

M6 - 11 Nm	M 8 - 25 Nm	M 10 - 50 Nm
M 12 - 87 Nm	M 14 - 138 Nm	M16 - 210 Nm











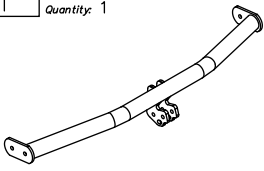
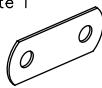

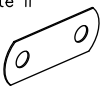
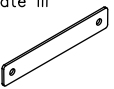
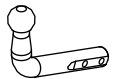
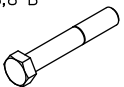
NOTE

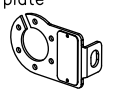
After install the towing hitch you should get adequate note in registration book (at authorised service station).The car should be equipped with:

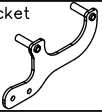
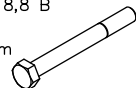
- Indicators
- Tow mirrors

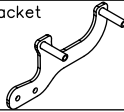
After 1000km check all bolts and nuts. The ball of towing hitch must be always kept clear and conserve with a grease.

Towing hitch equipment:

Pos. 1	Name: Main bar Quantity: 1	Pos. 6	Name: Fish-plate I Quantity: 2 Dim.: 96x36x2mm	Pos. 12	Name: Nut 8 B Quantity: 4 Dim.: M10
					
		Pos. 7	Name: Fish-plate II Quantity: 1 Dim.: 96x36x1mm	Pos. 13	Name: Fish-plate III Quantity: 2 Dim.: 240x40x4
					
Pos. 2	Name: Tow ball Quantity: 1	Pos. 8	Name: Bolt 8,8 B Quantity: 2 Dim.: M12x75mm	Pos. 14	Name: Plain washer Quantity: 6 Dim.: Ø 13 mm
					
Pos. 3	Name: Socket plate Quantity: 1	Pos. 9	Name: Bolt 8,8 B Quantity: 4 Dim.: M12x35mm	Pos. 15	Name: Plain washer Quantity: 4 Dim.: Ø 10,5 mm
					
Pos. 4	Name: Right bracket Quantity: 1	Pos. 10	Name: Bolt 8,8 B Quantity: 4 Dim.: M10x100mm	Pos. 16	Name: Spring washer Quantity: 6 Dim.: Ø 12,2 mm
					
Pos. 5	Name: Left bracket Quantity: 1	Pos. 11	Name: Nut 8 B Quantity: 4 Dim.: M12	Pos. 17	Name: Spring washer Quantity: 4 Dim.: Ø 10,2 mm
					
		Pos. 18	Name: Ball cover Quantity: 1		



PPUH AUTO-HAK S.J.

Produkcja Haków Holowniczych
Henryk & Zbigniew Nejman
76-200 SŁUPSK ul. Słoneczna 16K
tel/fax (059) 8-414-414; 8-414-413
E-mail: office@autohak.com.pl
www.autohak.com.pl

Towing hook (without electrical set)

Class: **A50-X** Cat. no. **G48**

Designed for:

Manufacturer: **RENAULT**

Model: **MODUS**

Type: **5 doors, VAN**

produced since 10.2004 till 01.2008

Technical data:

D-value: 5,77 kN

maximum trailer weight: **900 kg**

maximum vertical cup load: **75 kg**

Approval number according to Directive 94/20/EC: e20*94/20*0064*00

Foreword

This towing hitch is designed according to rules of safety traffic regulations. The towing hitch is a safety component and can be install only by qualified personnel. Any alteration or conversion of the towing hitch is prohibited and would lead to cancellation of design certification. Remove insulating compound and underseal from vehicle (if present) in the area of the matting surfaces of the towing hitch.

The vehicle manufacturer's specifications regarding trailer load and max. vertical cup load are decisive for driving whereat values for the towing hitch cannot be exceeded.

D-value formula:

$$\frac{\text{Max trailer weight [kg]} \times \text{Max vehicle weight [kg]}}{\text{Max trailer weight [kg]} + \text{Max vehicle weight [kg]}} \times \frac{9,81}{1000} = D \text{ [kN]}$$