

FITTING INSTRUCTION

| Clamp mark in acc. with | | Cables joining |
|-------------------------|-----|---------------------------|
| ISO | PN | |
| 1 | L | Left directional lights |
| 2 | + | Rear fog lights |
| 3 | 31 | Ground |
| 4 | R | Right directional lights |
| 5 | 58R | Right side parking lights |
| 6 | 54 | Stoplights |
| 7 | 58L | Left side parking lights |

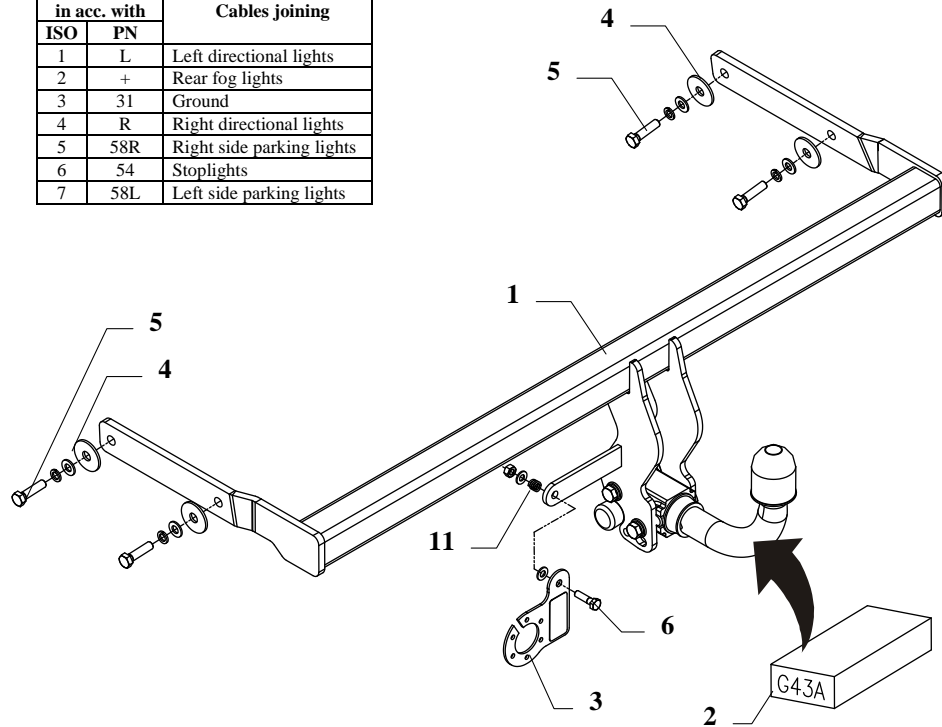

This towbar is designed to assembly in following car:
RENAULT MEGANE II, 4 doors, produced since 09.2003, catalogue no.

G43A

and is prepared to tow trailers max total weight **1300 kg** and max vertical load **75kg**.

From manufacturer

Thank you for buying our product. Their reliability has been confirmed in many tests. Reliability of towbar depends also on correct assembly and right operation. For this reasons we kindly ask to read carefully this instruction and apply to hints.

The towbar should be installed in points described by a car producer.

The instruction of the assembly

1. Disassemble a bumper and metal reinforcement (not used any more).
2. Slip main bar of the towbar (pos. 1) to chassis members and next screw it using bolts M10x40mm (pos. 5) from accessories (use flat washers – pos. 4).
3. Assemble a bumper.
4. Fix body of the automat and place tow-ball according to supplied instruction.
5. Fix the socket plate (pos. 3) as shown on the drawing.
6. Tighten all bolts according to the torque shown in the table.
7. Connect electric wires of 7-poles socket according to the instruction of the car. (Recommend to make at authorized service station)
8. Complete the paint coating damaged during instalment.

Torque settings for nuts and bolts (8,8):

| | | |
|--------------------|---------------------|---------------------|
| M6 - 11 Nm | M8 - 25 Nm | M10 - 50 Nm |
| M12 - 87 Nm | M14 - 138 Nm | M16 - 210 Nm |



NOTE

After install the towbar you should get adequate note in registration book (at authorised service station).The car should be equipped with:

- Indicators
- Tow mirrors

After 1000km of exploitation check all bolts and nuts. The ball of towbar must be always kept clear and conserve with a grease.

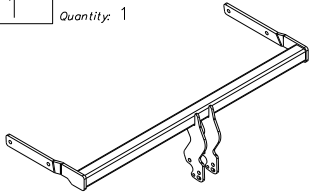
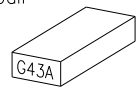
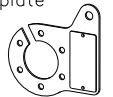
Towbar accessories:

| | | |
|---|---|--|
| Pos. 1 Name: Main bar Quantity: 1 | Pos. 4 Name: Washer Quantity: 4 Dim.: Ø 42x12x3 mm | Pos. 8 Name: Spring washer Quantity: 4 Dim.: Ø 10,2 mm |
|  | Pos. 5 Name: Bolt 8,8 B Quantity: 4 Dim.: M10x40mm | Pos. 9 Name: Plain washer Quantity: 2 Dim.: Ø 8,5 mm |
| Pos. 2 Name: Tow ball Quantity: 1 | Pos. 6 Name: Bolt 8,8 B Quantity: 1 Dim.: M8x30mm | Pos. 10 Name: Nut 8 B Quantity: 1 Dim.: M8 |
|  | Pos. 7 Name: Plain washer Quantity: 4 Dim.: Ø 10,5 mm | Pos. 11 Name: Spring Quantity: 1 |
| Pos. 3 Name: Socket plate Quantity: 1 |  |  |



PPUH AUTO-HAK S.J.

Produkcja Zaczepów Kulowych
Henryk & Zbigniew Nejman
76-200 SŁUPSK ul. Słoneczna 16K
tel/fax (059) 8-414-414; 8-414-413
E-mail: office@autohak.com.pl
www. autohak.com.pl

Towing hitch (without electrical set)

Class: **A50-X** Cat. no. **G43A**

Designed for:

Manufacturer: **RENAULT**

Model: **MEGANE II**

Type: **4 doors**

produced since 09.2003

Technical data:

D-value: 7,48 kN

maximum trailer weight: **1300 kg**

maximum vertical cup load: **75 kg**

Approval number according to Directive 94/20/EC: e20*94/20*1127*00

Foreword

This towbar is designed according to rules of safety traffic regulations. The towing hitch is a safety component and can be install only by qualified personnel. Any alteration or conversion of the towing hitch is prohibited and would lead to cancellation of design certification. Remove insulating compound and underseal from vehicle (if present) in the area of the matting surfaces of the towing hitch.

The vehicle manufacturer's specifications regarding trailer load and max. vertical cup load are decisive for driving, and values for the towing hitch cannot be exceeded.

D-value formula:

$$\frac{\text{Max trailer weight [kg]} \times \text{Max vehicle weight [kg]}}{\text{Max trailer weight [kg]} + \text{Max vehicle weight [kg]}} \times \frac{9,81}{1000} = D \text{ [kN]}$$