

FITTING INSTRUCTION

Clamp mark in acc. with		Cables joining
ISO	PN	
1	L	Left directional lights
2	+	Rear fog lights
3	31	Ground
4	R	Right directional lights
5	58R	Right side parking lights
6	54	Stoplights
7	58L	Left side parking lights

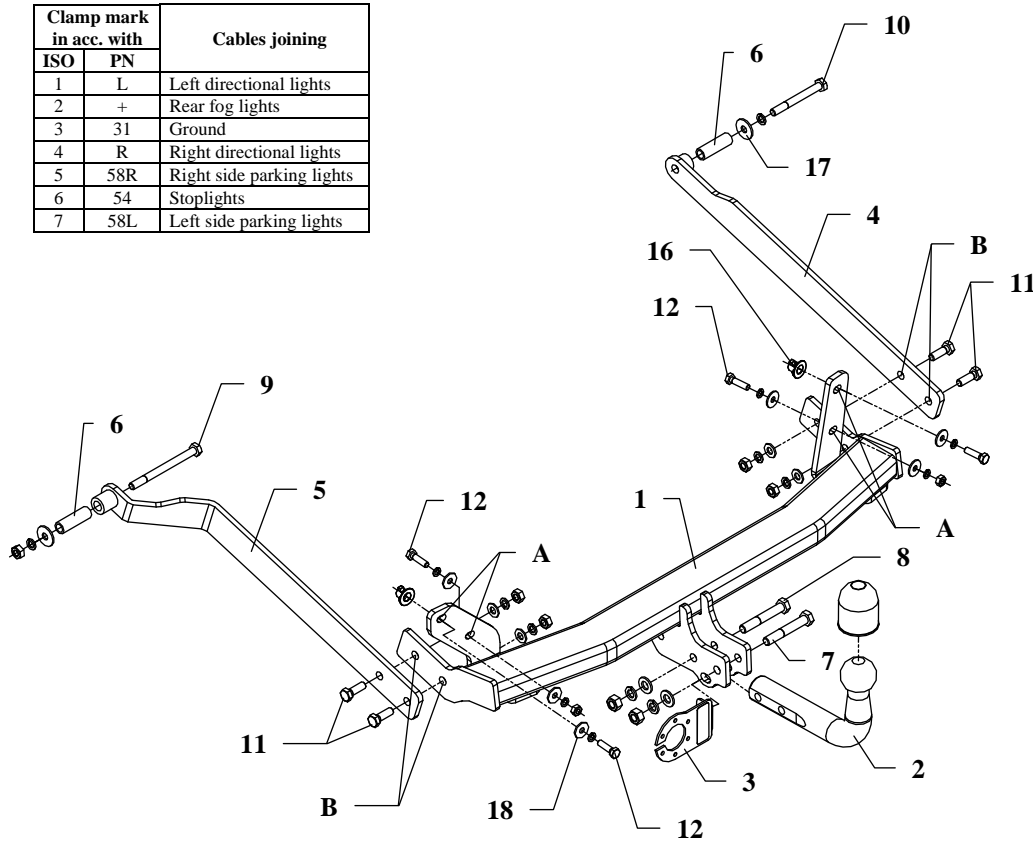

This towing hitch is designed to assembly in following cars:
RENAULT MEGANE I GRANDTOUR, ESTATE (KA), produced since 04.1999 till 08.2003, catalogue no. **G33** and is prepared to tow trailers max total weight **1350 kg** and max vertical load **75 kg**.

From manufacturer

Thank you for buying our product. Their reliability has been confirmed in many tests. Reliability of towing hitch depends also on correct assembly and correct exploitation. For this reasons we kindly ask to read carefully this instruction and apply to hints.

The towing hitch should be install in points described by a car producer.

The instruction of the assembly

1. From below the car, in rear slice, find plugged holes (on the left and right side). Open it and put caget nut in (pos. 16).
2. Main bar of the towing hitch (pos. 1) put from below and through holes (pos. A) and fix by bolts M8 as shown on the figure (use big washers pos. 18).
3. In original holes in chassis members put distance sleeves (pos. 6) – from outside.
4. To installed main bar (pos. 1) fix side brackets (pos. 4 and 5). Use bolts M10x30mm (pos. 11) through holes (pos. B).
5. Fix elements (pos. 4 and 5) through placed distance sleeves in chassis members and holes of the towing hitch by bolts M10x90mm (pos. 10) and by bolts M10x120mm (pos. 9).
6. Fix tow-ball (pos. 2) and socket plate (pos. 3) using bolts M12x75mm (pos. 7) and M12x70mm (pos. 8) from accessories.
7. Tighten all bolts according to the torque shown in the table.
8. Connect electric wires of 7-poles socket according to the instruction of the car. (Recommend to make at authorized service station)
9. Complete paint layer damaged during installation.

Torque settings for nuts and bolts (8,8):

M6 - 11 Nm	M 8 - 25 Nm	M 10 - 50 Nm
M 12 - 87 Nm	M 14 - 138 Nm	M16 - 210 Nm

NOTE

After install the towing hitch you should get adequate note in registration book (at authorised service station).The car should be equipped with:

- Indicators
- Tow mirrors

After 1000km check all bolts and nuts. The ball of towing hitch must be always kept clear and conserve with a grease.

Towing hitch accessories:

Pos. 1 Main bar PCS.: 1	Pos. 6 Distance sleeve ø17,2x2.35mm L=53mm PCS.: 2	Pos. 12 Bolt 8,8 B M8x30mm PCS.: 4	Pos. 18 Washer ø24xø8.4x2mm PCS.: 6
Pos. 2 Tow ball PCS.: 1	Pos. 7 Bolt 8,8 B M12x75mm PCS.: 1	Pos. 13 Nut 8 B M12 PCS.: 2	Pos. 19 Plain washer ø13mm PCS.: 2
Pos. 3 Socket plate PCS.: 1	Pos. 8 Bolt 8,8 B M12x70mm PCS.: 1	Pos. 14 Nut 8 B M10 PCS.: 5	Pos. 20 Plain washer ø10.5mm PCS.: 4
Pos. 4 Right bracket PCS.: 1	Pos. 9 Bolt 8,8 B M10x120mm PCS.: 1	Pos. 15 Nut 8 B M8 PCS.: 2	Pos. 21 Spring washer ø12.2mm PCS.: 2
Pos. 5 Left bracket PCS.: 1	Pos. 10 Bolt 8,8 B M10x90mm PCS.: 1	Pos. 16 Special nut M8 PCS.: 2	Pos. 22 Spring washer ø10.2mm PCS.: 6
	Pos. 11 Bolt 8,8 B M10x30mm PCS.: 4	Pos. 17 Washer ø30xø10.5x2.5mm PCS.: 2	Pos. 23 Spring washer ø8.2mm PCS.: 6
			Pos. 24 Ball cover PCS.: 1



PPUH AUTO-HAK Sp.J.

Produkcja Zaczepów Kulowych
Henryk i Zbigniew Nejman
76-200 SŁUPSK ul. Słoneczna 16K
tel/fax (059) 8-414-414; 8-414-413
E-mail: office@autohak.com.pl
www.autohak.com.pl

Towing hitch (without electrical set)

Class: **A50-X** Cat. no. **G33**

Designed for:

Manufacturer: **RENAULT**

Model: **MEGANE I GRANDTOUR**

Type: **ESTATE (KA)**

produced since 04.1999 till 08.2003

Technical data:

D-value: 7,56 kN

maximum trailer weight: **1350 kg**

maximum vertical cup load: **75 kg**

Approval number according to Directive 94/20/EC: e20*94/20*0247*00

Foreword

This towing hitch is designed according to rules of safety traffic regulations. The towing hitch is a safety component and can be install only by qualified personnel. Any alteration or conversion of the towing hitch is prohibited and would lead to cancellation of design certification. Remove insulating compound and underseal from vehicle (if present) in the area of the matting surfaces of the towing hitch. The vehicle manufacturer's specifications regarding trailer load and max. vertical cup load are decisive for driving, and values for the towing hitch cannot be exceeded.

D-value formula:

$$\frac{\text{Max trailer weight [kg]} \times \text{Max vehicle weight [kg]}}{\text{Max trailer weight [kg]} + \text{Max vehicle weight [kg]}} \times \frac{9,81}{1000} = D \text{ [kN]}$$