

FITTING INSTRUCTION

Clamp mark in acc. with		Cables joining
ISO	PN	
1	L	Left directional lights
2	+	Rear fog lights
3	31	Ground
4	R	Right directional lights
5	58R	Right side parking lights
6	54	Stoplights
7	58L	Left side parking lights

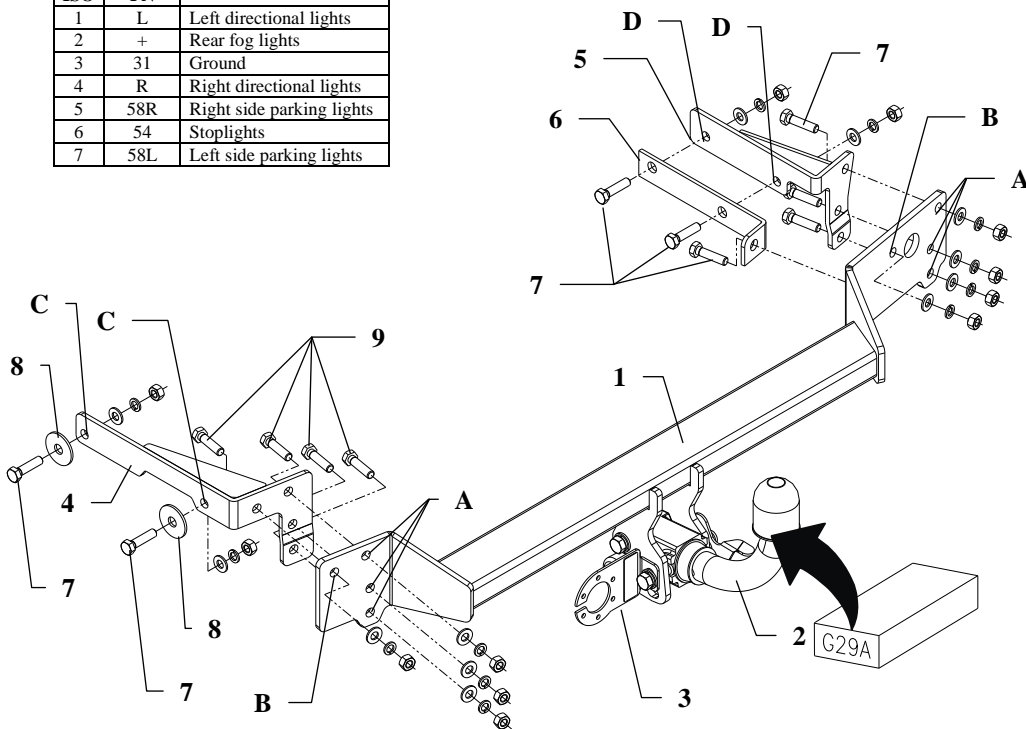

This towbar is designed to assembly in following car: **RENAULT CLIO II/CAMPUS, 3/5 doors, except Sport V6**, produced since 03.1998 till 06.2001 and produced since 07.2001 till 08.2005, catalogue no. **G29A** and is prepared to tow trailers max total weight **1200 kg** and max vertical mass **75 kg**.

From manufacturer

Thank you for buying our product. Their reliability has been confirmed in many tests. Reliability of towbar depends also on correct assembly and right operation. For this reasons we kindly ask to read carefully this instruction and apply to hints.

The towbar should be install in points described by a car producer.

The instruction of the assembly

1. Disassemble the bumper
2. Position the elements (pos. 5 and 6) to the right chassis member (find original holes)
 - position the element (pos. 5) to the right side
 - position the element (pos. 6) to the left side
3. Fix left bracket (pos. 4) to the left chassis member (find original holes), and then fix it through the holes (pos. C) using bolts M10x40mm (pos. 7).
4. Put main bar of the towbar (pos. 1) to the rear panel and fix it through the original holes and holes (pos. A and B) using bolts M10x40mm (pos. 7).
5. Reassemble the bumper.
6. Fix body of the automat and place tow-ball according to supplied instruction. Note! Remember to place socket plate (pos. 3) as shown on the drawing 1.
7. Tighten all bolts according to the torque shown in the table.
8. Connect electric wires of 7-poles socket according to the instruction of the car. (Recommend to make at authorized service station).
9. Complete paint layer damaged during installation.

Torque settings for nuts and bolts (8,8):

M6 - 11 Nm	M8 - 25 Nm	M10 - 50 Nm
M12 - 87 Nm	M14 - 138 Nm	M16 - 210 Nm







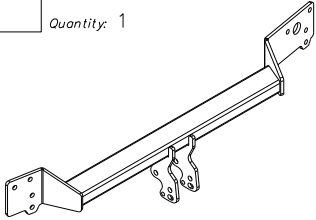
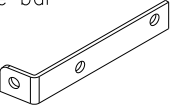
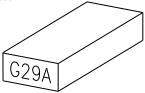

NOTE

After install the towbar you should get adequate note in registration book (at authorised service station).The car should be equipped with:

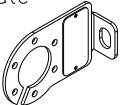
- Indicators
- Tow mirrors

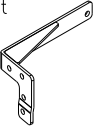
After 1000km of exploitation check all bolts and nuts. The ball of towbar must be always kept clear and conserve with a grease.

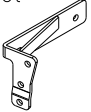
Towbar accessories:

Pos. 1	Name: Main bar Quantity: 1	Pos. 6	Name: Angle bar Quantity: 1
			
Pos. 2	Name: Tow ball Quantity: 1	Pos. 7	Name: Bolt 8,8 B Quantity: 4 Dim.: M12x25mm
			
Pos. 3	Name: Socket plate Quantity: 1	Pos. 8	Name: Nut 8 B Quantity: 12 Dim.: M10
			
Pos. 4	Name: Left bracket Quantity: 1	Pos. 9	Name: Washer Quantity: 2 Dim.: Ø42xØ13x3mm
			
Pos. 5	Name: Right bracket Quantity: 1	Pos. 10	Name: Plain washer Quantity: 12 Dim.: Ø 10,5 mm
			
		Pos. 11	Name: Spring washer Quantity: 12 Dim.: Ø 10,2 mm
			



PPUH AUTO-HAK S.J.

Produkcja Zaczepów Kulowych
Henryk & Zbigniew Nejman
76-200 SŁUPSK ul. Słoneczna 16K
tel/fax (059) 8-414-414; 8-414-413
E-mail: office@autohak.com.pl
www.autohak.com.pl

Towing hitch (without electrical set)

Class: **A50-X** Cat. no. **G29A**

Designed for:

Manufacturer: **RENAULT**

Model: **CLIO II/CAMPUS, except Sport V6**

Type: **3/5 doors**

produced since 03.1998 till 06.2001

and since 07.2001 till 08.2005

Technical data:

D-value: 6,54 kN

maximum trailer weight: **1200 kg**

maximum vertical cup load: **75 kg**

Approval number acc. to regulations EKG/ONZ 55.01: **E20-55R-01 4314**

Foreword

This towbar is designed according to rules of safety traffic regulations. The towing hitch is a safety component and can be install only by qualified personnel. Any alteration or conversion of the towing hitch is prohibited and would lead to cancellation of design certification. Remove insulating compound and underseal from vehicle (if present) in the area of the matting surfaces of the towing hitch. The vehicle manufacturer's specifications regarding trailer load and max. vertical cup load are decisive for driving whereat values for the towing hitch cannot be exceeded.

D-value formula:

$$\frac{\text{Max trailer weight [kg]} \times \text{Max vehicle weight [kg]}}{\text{Max trailer weight [kg]} + \text{Max vehicle weight [kg]}} \times \frac{9,81}{1000} = D \text{ [kN]}$$