

FITTING INSTRUCTION

Clamp mark in acc. with		Cables joining
ISO	PN	
1	L	Left directional lights
2	+	Rear fog lights
3	31	Ground
4	R	Right directional lights
5	58R	Right side parking lights
6	54	Stoptlights
7	58L	Left side parking lights

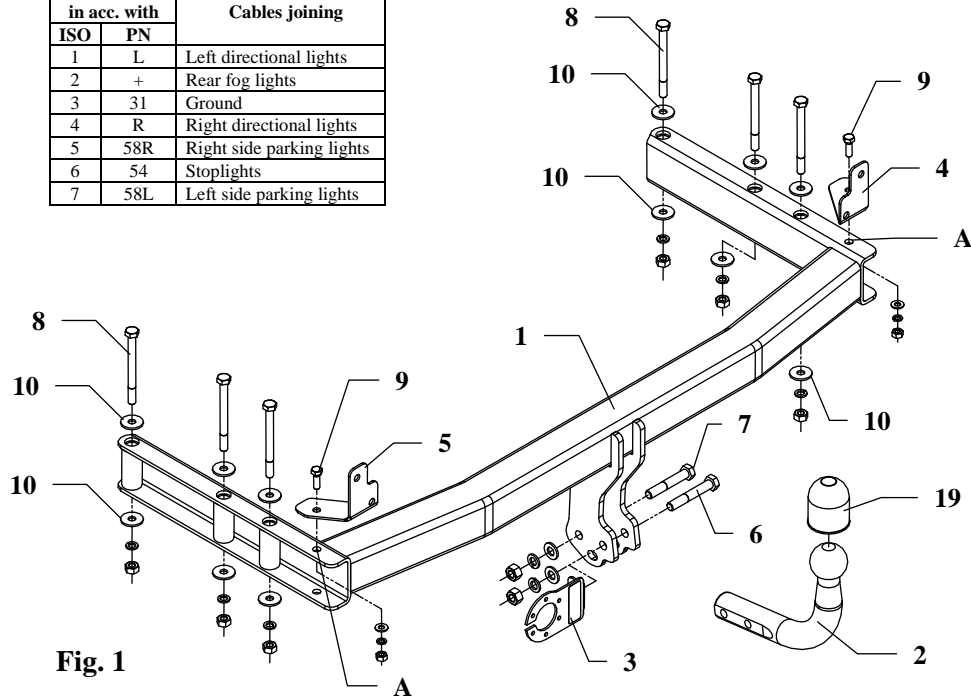

Fig. 1

This towbar is designed to assembly in following cars:
AUDI 80, 90, 4 door, Quattro (8C, B4), except RS, produced since 09.1991 till 12.1994, **AUDI 80 Avant, estale, Quattro (8C, B4), except RS**, produced since 09.1991 till 12.1995, catalogue no. **A03** and is prepared to tow trailers max total weight **1700kg** and max vertical load **75 kg**.

Torque settings for nuts and bolts (8,8):

M6 - 11 Nm	M8 - 25 Nm	M10 - 50 Nm
M12 - 87 Nm	M14 - 138 Nm	M16 - 210 Nm

NOTE

After install the towbar you should get adequate note in registration book (at authorised service station).The car should be equipped with:

- Indicators
- Tow mirrors

After 1000km of exploitation check all bolts and nuts. The ball of towbar must be always kept clear and conserve with a grease.

The instruction of the assembly

1. To install the towbar you have to disassemble the bumper and next
 - disassemble handles of the bumper
 - cut off three brackets (see figure 3)
 - in bottom edge of bumper, in axis, cut off fragment 50x60mm
2. Enlarge enter of chassis members by cut fragment according to figure 2.
3. Through holes of towbar pos. A fix handles (pos. 4 and 5) using bolts M8x25mm (pos. 9).
4. Fix bumper to the main bar of the towbar using original bolts after disassembling of handles of the bumper
5. Main bar of the towbar together with bumper. slip into chassis members in this way, so holes of towbar agree with original prepared holes and fix from inside bumper using bolts M10x110mm (pos. 8) as shown in figure 1.
6. Tighten all bolts according to the torque shown in the table.
7. Fix tow-ball (pos. 2) and socket plate (pos. 3) using bolts M12x75mm (pos. 6) and M12x70mm (pos. 7) from accessories.
8. Connect the electric wires according to the instructions of the car. (Recommended to make at service station).
9. Supplement the paint coating damaged during assembly.

Fig. 2

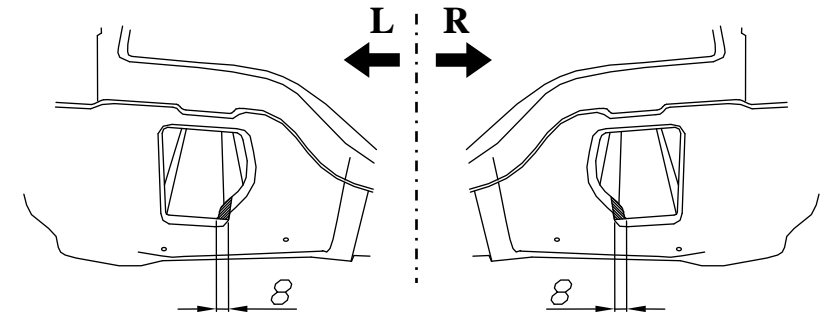
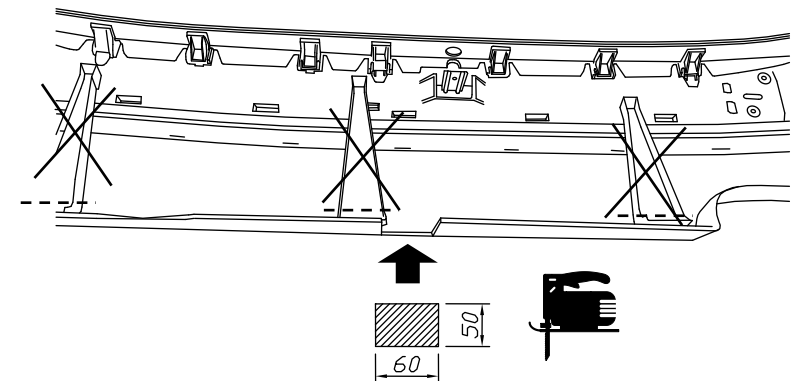
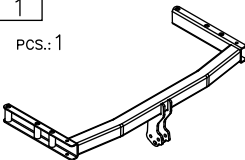
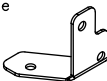



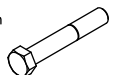

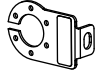
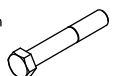

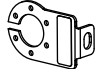
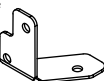
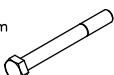

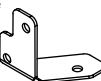





Fig. 3



Towbar accessories:

Pos. 1 Main bar  PCS.: 1	Pos. 5 Left handle  PCS.: 1	Pos. 10 Plain washer $\phi 30 \times \phi 10,5 \times 2,5 \text{ mm}$  PCS.: 12	Pos. 15 Spring washer $\phi 8,2 \text{ mm}$  PCS.: 2
Pos. 2 Tow ball  PCS.: 1	Pos. 6 Bolt 8,8 B $M12 \times 75 \text{ mm}$  PCS.: 1	Pos. 11 Plain washer $\phi 13 \text{ mm}$  PCS.: 2	Pos. 16 Nut 8 B $M12$  PCS.: 2
Pos. 3 Socket plate  PCS.: 1	Pos. 7 Bolt 8,8 B $M12 \times 70 \text{ mm}$  PCS.: 1	Pos. 12 Plain washer $\phi 8,5 \text{ mm}$  PCS.: 2	Pos. 17 Nut 8 B $M10$  PCS.: 6
Pos. 4 Right handle  PCS.: 1	Pos. 8 Bolt 8,8 B $M10 \times 110 \text{ mm}$  PCS.: 6	Pos. 13 Spring washer $\phi 12,2 \text{ mm}$  PCS.: 2	Pos. 18 Nut 8 B $M8$  PCS.: 2
Pos. 9 Bolt 8,8 B $M8 \times 25 \text{ mm}$  PCS.: 2	Pos. 14 Spring washer $\phi 10,2 \text{ mm}$  PCS.: 6	Pos. 19 Ball cover  PCS.: 1	



PPUH AUTO-HAK Sp.J.

Produkcja Zaczepów Kulowych
 Henryk & Zbigniew Nejman
 76-200 SŁUPSK ul. Słoneczna 16K
 tel/fax (059) 8-414-414; 8-414-413
 E-mail: office@autohak.com.pl
 www. autohak.com.pl

Towing hitch (without electrical set)

Class: **A50-X** Cat. no. **A03**

Designed for:

Manufacturer: **AUDI**

Model: **80, 90**

Type: **4 door, QUATTRO (8C, B4), except RS**

produced since 09.1991 till 12.1994

Model: **80 AVANT**

Type: **estale, QUATTRO (8C, B4), except RS**

produced since 09.1991 till 12.1995

Technical data:

D-value: 8,3 kN

maximum trailer weight: **1700 kg**

maximum vertical cup load: **75 kg**

Approval number acc. to regulations EKG/ONZ 55.01: **E20-55R-01 1079**

Foreword

This towbar is designed according to rules of safety traffic regulations. The towing hitch is a safety component and can be install only by qualified personnel. Any alteration or conversion of the towing hitch is prohibited and would lead to cancellation of design certification. Remove insulating compound and underseal from vehicle (if present) in the area of the matting surfaces of the towing hitch.

The vehicle manufacturer's specifications regarding trailer load and max. vertical cup load are decisive for driving, and values for the towing hitch cannot be exceeded.

D-value formula:

$$\frac{\text{Max trailer weight [kg]} \times \text{Max vehicle weight [kg]}}{\text{Max trailer weight [kg]} + \text{Max vehicle weight [kg]}} \times \frac{9,81}{1000} = D \text{ [kN]}$$